

Teaching AS Physics Practical Skills

Contents

Introduction	1
Why should I read this booklet?	1
How much teaching time should I allocate to practical work?	1
Can I use the practicals in these booklets in a different order?	1
What resources will I need?	2
Is there a limit to the class size?	2
Why should I teach my students practical skills?	3
Points to consider	3
What are the practical skills required by this course?	5
Summary of each of the seven skills	5
A sequence for introducing the skills	7
Ways of doing practical work	9
Keeping records	12
How is a practical activity organised?	13
Teaching AS skills	15
Teaching students to set up and manipulate apparatus	15
Teaching students to make measurements and observations	15
Teaching students to record and present observations and data	17
Teaching students to analyse data and draw conclusions	19
Teaching students to evaluate procedures	21
Designing a practical course for the AS year	23
Planning the course	23
Planning lessons and teaching the course	24
Planning for a circus	25
Appendix 1: Possible AS practical activities	26
Appendix 2: Examples of AS practicals	37
Terminal Velocity	38
Acceleration down a Slope	42
Triangle of Forces Board	47
Finding the Mass of a Metre Rule using the Principle of Moments	51
Finding the Densities of Different Materials	55
Elasticity and Springs	60
Finding the Young Modulus of a Wire	65
Measuring the Resistivity of a Wire	70
Potential Divider	74
Measuring g using a Pendulum	78
Appendix 3: Useful resources	82

Introduction

You may have been teaching AS and A level physics for many years or perhaps you are new to the game. Whatever the case may be, you will be keen to ensure that you prepare your students as effectively as possible for their examinations. The use of a well-structured scheme of practical work will certainly help in this ambition. However it can do so much more. Science students who are thoroughly trained and experienced in practical skills will have a 'feel' for the subject and a confidence in their own abilities that is far greater than that of students with a purely theoretical background. It is true that there are branches of physics that might be described as purely theoretical but they are in the minority. Essentially, physics is an experimental subject and we owe it to our students to ensure that those who pursue science further have the necessary basic practical skills to take forward into their future careers. Furthermore, the basic skills of planning, analysis and evaluation will be of great value to those who pursue non-science careers.

Why should I read this booklet?

You may be wondering why you should need a booklet like this. If your practical skills are of a high order and you feel confident teaching these skills to others, you probably don't need it (although you might find some of the exercises described in the appendices useful). However, if you are like the majority of us, a little help and support is likely to be appreciated. This booklet aims to provide at least some of this support.

The booklet is designed for the teacher, not for the student. Its objective is to provide a framework within which teachers can develop their confidence in teaching practical skills. Experience suggests that as this confidence grows, the time that teachers are prepared to spend on teaching practical skills also grows.

How much teaching time should I allocate to practical work?

The syllabus stipulates that at least 20% of teaching time should be allocated to practical work. This is in addition to any time the teacher chooses to use for practical demonstrations to illustrate the theory syllabus.

This emphasis on practical work is not misplaced. If the specific practical papers (papers 3 and 5) are considered in isolation, they represent 23% of the examination. However, practical work is not merely a necessary preparation for the practical papers. Questions in the theory papers may also assume an understanding of experimental data or practical techniques. The theory papers also give a considerable weighting to the skills of handling, applying and evaluating information, and one of the ways in which students acquire these skills is through their course of practical work.

In planning a curriculum, teachers should therefore expect to build in time for developing practical skills. If, for example, the total teaching time allowed for Physics is 5 hours per week over 35 weeks, then a minimum of 1 hour per week for practical work should be built into the plan. In this way, over the year a minimum of 35 hours for practical work is made available. Bearing in mind the weighting given to assessment objectives that relate to information handling and problem solving, 35 hours of practical work should be regarded as an absolute minimum.

Can I use the practicals in these booklets in a different order?

It is assumed in these booklets that for A level candidates, the AS work will be taught in the first year of the course, with the A2 work being covered in the second year. If the linear A Level assessment route is used, care should be taken with regard to the order in which practical exercises are used, as the skills practiced in these booklets are hierarchical in nature, i.e. the basic skills established in the AS booklet are extended and developed in the

A2 booklet. Thus, students will need to have practiced basic skills using AS exercises before using these skills to tackle more demanding A2 exercises.

The exercises in these booklets are given in syllabus order. A teacher may well decide to use a different teaching sequence, but the point made above regarding AS and A2 exercises still applies.

What resources will I need?

For a practical course in A-level physics to be successful, it is not necessary to provide sophisticated equipment. Some of the more advanced practicals in these booklets may require less easily obtainable equipment, but the vast majority can be performed using the basic equipment and materials in the laboratory.

A list of basic resources regularly required for assessment may be found in the syllabus. A more detailed list of apparatus suitable for teaching purposes may be found in the CIE booklet '*Planning For Practical Science in Secondary Schools*'.

Is there a limit to the class size?

There is a limit to the class size that is manageable in a laboratory situation, particularly when students may be moving about. The actual size may be determined by the size of the room, but as a general guide, 15 - 20 students is the maximum that one teacher can reasonably manage, both for safety reasons and so that adequate support can be given to each student. Larger numbers would require input from another person with appropriate qualifications, or alternatively would require the class to be divided into two groups for practical lessons.

Why should I teach my students practical skills?

Although this section is likely to be read once only, it is arguably the most important, for, if it convinces some readers that practical work is an essential part of physics and underpins the whole teaching programme, one of the aims of publishing this booklet will have been achieved.

Points to consider

- It's fun! The majority of students thoroughly enjoy practical work. The passion that many scientists have for their subject grew out of their experiences in practical classes. Students who enjoy what they are doing are likely to carry this enthusiasm with them and so be better motivated in all parts of the course.
- Learning is enhanced by participation as students tend to remember activities they have performed more easily, thus benefiting their long-term understanding of the subject. Students who simply memorise and recall facts find it difficult to apply their knowledge to an unfamiliar context. Experiencing and using practical skills helps develop the ability to use information in a variety of ways, thus enabling students to apply their knowledge and understanding more readily.
- The integration of practical work into the teaching programme quite simply brings the theory to life. Teachers often hear comments from students such as "I'm glad we did that practical because I can see what the book means now." and "It's much better doing it than talking about it."
- Physics, in common with other sciences, is by its very nature a practical subject – both historically and in the modern world. The majority of students who enter careers in science need to employ at least basic practical skills at some time in their career.
- A practical course plays a part in developing many cross-curricular skills including literacy, numeracy, ICT and communication skills. It develops the ability to work both in groups and independently with confidence. It enhances critical thinking skills and it requires students to make judgements and decisions based on evidence, some of which may well be incomplete or flawed. It helps to make students more self-reliant and less dependent on information provided by the teacher.
- The skills developed are of continued use in a changing scientific world. While technological advances have changed the nature of many practical procedures, the investigative nature of practical science is unchanged. The processes of observation, hypothesis formation, testing, analysis of results and drawing conclusions will always be the processes of investigative science. The ability to keep an open mind in the interpretation of data and develop an appreciation of scientific integrity is of great value both in science and non-science careers.
- Practical work is not always easy and persistence is required for skills and confidence to grow. Students often relish this challenge and develop a certain pride in a job well done.
- The more experience students have of a variety of practical skills, the better equipped they will be to perform well in the practical exams, both in terms of skills and confidence. Some teachers have argued that the skills required for paper 3 can be developed simply by practising past papers. However, experience suggests that this approach does not usually produce good results, and that confidence in practical work will be greatly enhanced by a broader range of practical experience. Similarly for paper 5, it has been suggested that planning, analysis and evaluation could be taught theoretically. However, without hands-on experience of manipulating their own data, putting their plans into action and evaluating their own procedures and results, students will find this section difficult and will be at a distinct disadvantage in the examination. Those students

who achieve the highest grades do so because they can draw on personal experience, and so are able to picture themselves performing the procedure they are describing, or recall analysing their own results from a similar experiment. Students with a bank of practical experience are much more likely to perform well than those with limited practical skills.

What are the practical skills required by this course?

The syllabus specifies the practical skills to be assessed by providing generic mark schemes for the practical papers. These mark schemes divide practical skills into four broad areas.

- Manipulation, measurement and observation AS
- Presentation of data and observations AS
- Analysis, conclusions and evaluation AS and A2
- Planning A2

For teaching purposes, it is helpful to subdivide the first and third of these broad areas into slightly narrower ones. Students will also find it helpful to think about the sequence in which practical skills are used in a typical scientific investigation.

This course addresses practical skills under seven headings that contribute to the overall understanding of scientific methodology. In a scientific investigation these would be applied in the following sequence.

- 1 Planning the experiment**
- 2 Setting up and manipulating apparatus**
- 3 Making measurements and observations**
- 4 Recording and presenting observations and data**
- 5 Analysing data and drawing conclusions**
- 6 Evaluating procedures**
- 7 Evaluating conclusions**

It is easy to see how these seven skills are related to the four areas in the syllabus.

The emphasis of the AS part of the course is on skills 2, 3, 4, 5 and 6. In other words, students have to master the basic skills of manipulating apparatus, making measurements, displaying their data in tables and on graphs, and drawing conclusions. They also have to learn to critically evaluate the experimental procedures by identifying limitations and sources of error and by suggesting improvements.

The A2 syllabus concentrates on skills 1, 5 and 7 – the higher-level skills of planning, data analysis and evaluation. All of the skills developed in the AS part of the course are assumed to have been mastered and skill 5 is extended and deepened. The A2 skills can only be developed by allowing students to take a greater degree of control over the procedures they use in practical classes.

Summary of each of the seven skills

Full details of the requirements for each of these skills may be found in the syllabus. What follows below is a brief summary of the skills involved.

1 Planning

- **Defining the problem**

Students should be able to use information provided about the aims of the investigation, or experiment, to identify the key variables.

- **Methods of data collection**

The proposed experimental procedure should be workable. It should, if the apparatus were to be assembled appropriately, allow data to be collected without undue difficulty. There should be a description, including clear labelled diagrams, of

how the experiment should be performed and how the key variables are to be controlled. Equipment, of a level of precision appropriate for the measurements to be made, should be specified.

- **Method of analysis**

Students should be able to describe the main steps by which their results would be analysed in order to draw valid conclusions. This may well include the proposal of graphical methods to analyse data.

- **Safety considerations**

Students should be able to carry out a simple risk assessment of their plan, identifying areas of risk and suggesting suitable safety precautions to be taken.

2 Setting up and manipulating apparatus

Students must be able to follow instructions, whether given verbally, in writing or diagrammatically, and so be able to set up and use the apparatus for experiments correctly. They will need to be able to work with a variety of different pieces of apparatus and to work from circuit diagrams.

3 Making measurements and observations

Whilst successfully manipulating the experimental apparatus, students need to be able to make measurements with accuracy and/or to make observations with clarity and discrimination. They may need to be able to use specific measuring instruments and techniques, such as Vernier scales, cathode-ray oscilloscopes, or Hall probes. They need to be able to manage their time while they make measurements, and to be able to make decisions about when it is appropriate to repeat measurements. They need to organise their work so that they have the largest possible range of readings and so that the readings are appropriately distributed within that range. They should be able to identify and deal with results which appear anomalous.

4 Recording and presenting observations and data

Observations, data and reasoning need to be presented in ways that are easy to follow and that accord with conventional good practice.

- **Tables of results**

The layout and contents of a results table, whether it is for recording numerical data or observations, should be decided before the experiment is performed. 'Making it up as you go along' often results in tables that are difficult to follow and don't make the best use of space. Space should be allocated within the table for any manipulation of the data that will be required. The heading of each column must include both the quantity being measured and the units in which the measurement is made. Readings made directly from measuring instruments should be given to the number of decimal places that is appropriate for the measuring instrument used (for example, readings from a metre rule should be given to the nearest mm). Quantities calculated from raw data should be shown to the correct number of significant figures.

- **Graphs**

Students should label the axes of their graphs clearly with the quantity, unit and scale all clearly shown in accordance with conventional good practice. Scales should be chosen so that the graph grid is easy to use and so that the plotted points occupy the majority of the space available. All of the points in the table of results should be plotted accurately. Students should be able to draw curves, tangents to curves or lines of best fit.

- **Display of calculations and reasoning**

Where calculations are done as part of the analysis, all steps of the calculations must be displayed so that thought processes involved in reaching the conclusion are clear to a reader. Similarly, where conclusions are drawn from observational data, the key steps in reaching the conclusions should be reported and should be clear, sequential and easy to follow.

5 Analysing data and drawing conclusions

Students should be able to calculate the gradient and intercepts of a line, including finding the intercepts when a false origin has been used on the graph. They should be able to use these to find the equation of the line of best fit through their points. They should be able to relate an equation predicted by theory to the equation of their line of best fit or to their data, and hence to find the values of constants or to draw conclusions about the veracity of the theoretical prediction. They should be able to use the idea of proportionality in their reasoning. They should be able to make predictions or hypotheses based on their data.

In the AS part of the course, students would normally be told what quantities to calculate, what graph to plot and would be led through the analysis. In the A2 part of the course, students would normally be expected to be able to plan the analysis for themselves. This would normally include deciding what quantities to plot in order to obtain a straight-line graph, deciding how to calculate these quantities from their raw data, and deciding how to reach a conclusion from their graph.

6 Evaluating procedures

Students should be able to identify the limitations and weaknesses of experimental procedures. To be able to do this effectively, they must have a clear idea of the purpose of the experiment, and they must have carried out the procedure for themselves. They should be able to make reasonable estimates of the uncertainties in the quantities they have measured directly, and to compare these so that they can identify the largest sources of error. They should be able to suggest improvements to the experimental procedure which would improve the accuracy or reliability of the experiment.

7 Evaluating conclusions

This skill is primarily concerned with the treatment of errors. Where the outcome of an experiment is the value of a constant, the treatment of errors should lead to an estimate of the uncertainty in the student's value. Where the experiment is a test of a hypothesis, the treatment of errors should allow the student to discuss the validity of their conclusion in terms of the precision of the experimental procedures.

As part of the treatment of errors, students should be able to make estimates of the uncertainties in their measurements, calculate the uncertainties in derived quantities, display error estimates in tables of results, plot error bars on their graphs, and estimate the uncertainties in their calculations of gradients and intercepts.

A sequence for introducing the skills

The above list shows the seven skills in the order in which they would be used in an extended investigation. It is not suggested that these skills should be taught in this order (although students will find it helpful to understand how the skills fit together in an investigation).

Students who are new to practical work will initially lack the basic manipulative skills, and the confidence to use them. It would seem sensible, therefore, to start practical training with skills 2 and 3, initially with very simple tasks and paying attention to the establishment of safe working practices. These short initial exercises should focus on training students in the setting up of common items of apparatus (such as power supplies and stands, bosses and

clamps) and in the use of simple measurement techniques (such as the use of rules, stopwatches and electrical meters).

Once a measure of confidence in their manual dexterity has been established, AS students can move on to exercises that require skills 4 and 5 to be included. The exercises should be simple at first and grow in complexity. Extensive experience in carrying out practical procedures allows students to gain awareness of appropriate quantities and to become more organised in the management of time and the recording of data as it is collected.

It is likely that skill 6, Evaluating Procedures, will be the most difficult to learn at AS level. Critical self-analysis does not come easily to many people. 'My experiment worked well' is a common – and inadequate – student evaluation of an experiment. If students are to master this skill, they need to begin by developing an appreciation of the reliability and accuracy inherent in the equipment and procedures they are using. Exercises with less reliable outcomes can be used to provide more scope for the evaluation of procedural, technical or apparatus weaknesses.

In the AS year, most practical tasks will include instructions on what apparatus to use, how to set it up, what data to collect, and what graphs to plot. The skills under development in the AS year are concerned with being able to carry out these tasks effectively, and to evaluate what they have been asked to do. In the A2 year, students should begin to take more control over decision-making. This will include some exercises to develop skill 5: such exercises might provide instructions on what apparatus to use and what data to collect, but leave students to decide on how to conduct the analysis of their data, including decisions about what graph to plot. Practical work at this stage will also include some exercises to develop some aspects of skill 1, for example by telling students what data they need to collect but requiring them to decide how to collect it with the apparatus provided.

The evaluation of conclusions, skill 7, is essentially about the propagation of errors. This requires a high degree of familiarity not only with the basic ideas of uncertainty in measurements but also with the analysis of experimental data, and so is an A2 skill. This skill should be introduced early in the A2 year and students should then regularly be required to practice their skill with the treatment of errors.

Planning is arguably the most demanding of the seven skills. For it to be effective, students need to be very well grounded in skills 2-6, so that they can anticipate the different stages involved in the task, and can provide the level of detail required. It is for this reason that planning skills are not assessed at AS level but form part of the A2 assessment. Candidates cannot be taught to plan experiments effectively unless, on a number of occasions, they are required:

- to plan an experiment;
- to perform the experiment according to their plan;
- to evaluate what they have done.

Ways of doing practical work

Physics teachers should expect to use practical experiences as a way to enhancing learning. Practical activities should form the basis on which to build knowledge and understanding. They should be integrated with the related theory, offering opportunities for concrete, hands-on, learning rather than as stand-alone experiences. In planning a scheme of work it is important to consider a mosaic of approaches that include those that allow students to participate in their own learning.

- Some practical activities should follow the well established structure that includes a detailed protocol to follow. Such well-structured learning opportunities have a vital role to play in introducing new techniques.
- Other practical activities should offer the students the opportunity to devise their own plan and to apply their plan to solving a problem. The excitement generated by such autonomy provides a stimulus to engage a student's interest and challenge their thinking.

Practical activities may be used as a tool to introduce new concepts – for example by investigating the properties of new circuit components or of pieces of polaroid, followed up by theoretical consideration of the reasons for the results obtained. On other occasions, practical work can be used to support and enhance the required knowledge and understanding – for example in building upon a theoretical consideration of diffraction with a series of practicals involving light, water waves and microwaves. In all cases, learning will be enhanced most effectively by practical work that encourages students to be involved, to think, and to apply and use their knowledge, understanding and skills.

There are many strategies by which practical work can be integrated into a scheme of work. Teachers should use a variety of methods. Some of the ways of delivering practical work enable the teacher to interact on a one-to-one basis with individual students, which allows a teacher to offer support at a more personal level and develop a greater awareness of an individual student's needs.

The choice of the specific strategy to use will depend on such issues as class size, laboratory availability, the availability of apparatus, the level of competence of the students, availability and expertise of technical support, the time available, the intended learning outcomes for the activity, and safety considerations. The following are some possible strategies for delivery of practical work.

- **Teacher demonstrations**

Teacher demonstrations require less time than full class practicals, but give little opportunity for students to develop manipulative skills or gain familiarity with equipment. Careful planning can give opportunity for limited student participation. Teacher demonstrations are a valuable way of showing an unfamiliar procedure at the start of a practical session, during which students go on to use the method themselves.

Considerations when deciding whether to do a teacher demonstration might include:

- Safety** – some exercises carry too high a risk factor to be performed in groups.
- Apparatus** – complicated procedures or those using limited resources
- Time** – demonstrations usually take less time
- Outcome** – some results are difficult to achieve and may be beyond the skill level of most of the students. A failed experiment may be seen as a waste of time, although it may allow students to learn from their mistakes.
- Students' attention** – a danger is that the attention of some students will drift.
- Manipulative experience** – the teacher gets experience, the students' don't.

There are many good reasons for the teacher performing a demonstration but do be aware that most students have a strong preference for hands-on experimentation. So, where possible, do let them do it!

- **Group work**

Whole class practical sessions. These have an advantage in terms of management as all the students are doing the same thing. Students may be working individually, in pairs or in small groups. Integrating this type of practical is straightforward as lessons beforehand can be used to introduce the context and following lessons can be used to draw any conclusions and to develop evaluation. Where specialised equipment or expensive materials are in short supply this approach may not be feasible.

Small group work. This can provide a means of managing investigations that test a range of variables and collect a lot of measurements. Although the same procedure may be performed, each small group of students collects only one or a few sets of data which are then pooled. The individual student has the opportunity to develop their subject specific skills. Part of the role of the teacher is to monitor and maintain safety and also to enable and persuade reluctant learners to take part. Group work aids personal development as students must interact and work co-operatively.

Considerations when deciding whether to do group work might include:

- i **Learning** – successful hands-on work will reinforce understanding; also, students will learn from each other.
- ii **Confidence** – this will grow with experience
- iii **Awareness/insight** – should grow with experience
- iv **Team building** – a most desirable outcome.
- v **Setting out** – all students doing the same thing is easier for the technicians
- vi **Confusion** – incomplete, ambiguous or confusing instruction by the teacher will waste time while the instructions are clarified but may also compromise safety and restrict learning.
- vii **Opting out** – some students will leave it for others to do and so learn very little.
- viii **Safety** – constant vigilance is essential.
- ix **DIY** – the urge to adapt their experiments, to ‘see what would happen if’, must be strictly dealt with.
- x **Discipline** – practical time must not be allowed to become ‘play time’.

Working in groups, whether as part of a whole-class situation or where groups are working as parts of a whole, is probably the preferred option for many students. At A level, it is highly desirable to include opportunities for students to work on their own, developing their own skills and independence. In Papers 31 and 32, a student’s practical skills will be assessed on an individual basis, so an individual’s experience, competence and confidence are of considerable importance.

- **Circus of experiments**

A circus comprises of a number of different exercises that run alongside each other. Individual or groups of students work on the different exercises and, as each exercise is completed, move on to the next one. These are a means by which limited resources can be used effectively.

There are two basic approaches. Firstly, during a lesson a number of short activities may be targeted at a specific skill. Alternatively, over a series of lessons, a number of longer practical activities are used, addressing a variety of skills. The circus arrangement may be

more difficult to manage as the students are not all doing the same activity. This puts more pressure on the teacher as they have to cope with advising and answering questions from a variety of investigations. With circuses spread over a number of sessions, careful planning is needed to enable the teacher to engage each group of students and to maintain a safe environment. In these situations it is useful to have a few of the circus activities that involve no hands-on practical work, using data response based simulations or other activities. In this way the teacher can interact with groups that need a verbal introduction or short demonstration and can monitor their activities more effectively.

Considerations when deciding whether to do a circus of experiments might include:

- i **Apparatus** – if the amount of apparatus used in an exercise is limited, students are able to use it in rota.
 - ii **Awareness** – students by observing their peers will become more aware of the pitfalls of the exercise and so will learn from the experience of others.
 - iii **Safety** – different exercises may well carry different safety risks, all of which would need to be covered.
 - iv **Setting out** – students doing different exercises will make it more difficult for the technicians.
 - v **Opting out** – some students may be tempted to ‘borrow’ the results of earlier groups.
- **Within theory lessons**

This option should be considered whenever it is viable. It is likely that the practical work would be by demonstration, as this would take less time. Given the power of visual images, the inclusion of a short practical to illustrate a theoretical point will reinforce that point and so aid the learning process. It is critical, however, that the practical works correctly, otherwise the flow of the lesson is disrupted and confidence in the theory may be undermined. The exercise should therefore be practiced beforehand.

- **Project work**

Projects are a means by which a student’s interest in a particular topic, which is not always directly on the syllabus, can be used to develop investigative skills. This sort of investigative work can be individual, or a group activity. Once the project is underway, much of the work can be student-based, although if it is practical it needs to be undertaken under the supervision of the teacher for safety reasons. Care is needed in selecting the topics and setting a time scale, so that the relevance is maintained to the syllabus context.

- **Extra-curricular clubs**

The role that these can play is in stimulating scientific enquiry methods. There are a number of ways of using clubs. One way is to hold the club session during the teaching day so that all students can attend. In effect this becomes additional lesson time in which students can practice investigative skills, including laboratory work. Such laboratory work involves materials that have a cost, which must be planned for beforehand. If however the club is held outside the teaching day it may be voluntary. Syllabus-specific activities should be limited and the most made of the opportunities for exciting work unrelated to syllabuses. Students who do attend the club could be used as a teacher resource by bringing back their findings to a classroom session.

Keeping records

Students often find it a problem to integrate the practical work and the theory. This is particularly true when a circus of experiments or a long-term investigation or project is undertaken. Some potential issues include:

- Some students use odd scraps of paper in the laboratory, which are lost or become illegible as water is spilled on them. One important criterion is that students are trained to immediately and accurately record results.
- Practical procedures may be provided on loose sheets of paper which are subsequently lost, or students write down the results from a teacher demonstration. In either situation, students end up with results but no procedure or context.
- When results take a period of time to collect, analysis becomes isolated from the context of the investigation and may not be completed.

The key to minimising these issues is to train students into good working practices. This is particularly important in colleges where students join at the start of their A levels from a variety of feeder schools. It is also vital for students with specific learning difficulties that affect their ability to organise their work such as dyslexia and Asperger's syndrome.

Students may be encouraged to integrate the practical in the same file as the theory. Alternatively, students may be encouraged to keep an entirely separate practical book or file. Loose leaf files make it easy to add to the file, but may make it easier to mix up or lose items. Exercise books can be used but students should be encouraged to glue worksheets and their laboratory records into the book so that they are not lost. Depending on how they learn, individuals may vary in their preferred method. Whichever option is chosen, students need to be encouraged to relate their investigations to the appropriate theory and to regard it as something that needs to be thoroughly assimilated.

- Integrating the materials generated by practical work with the notes and other items from the learning of theory can be achieved by interspersing the records of investigations with the relevant section of theory. This may still require cross-referencing where several learning outcomes and assessment objectives are targeted by work.
- Keeping a separate practical book enables records of all the practical investigations to be kept in one place. Students need training to manage practical files effectively, particularly in keeping the contexts and cross referencing to the theory. If care is not taken to develop and keep up these skills, students may perceive practical work as something entirely different from theory.
- An intermediate between these two extremes is having a separate section for practical investigations in each student's file with each syllabus section and cross referenced to the relevant theory.

How is a practical activity organised?

Preparing for practical work needs thought and organisation. The practical work may be an activity that forms part of a lesson, it may comprise an entire lesson, or it may be an investigation designed to last for several lessons. In every case, thorough preparation is a key prerequisite to success.

Practical and investigative work should be integrated into the programme of study. The scheme of work should identify appropriate practical investigative experiences for use at the most suitable time. In designing the scheme of work,

- the resource implications should be considered in terms of equipment and materials in stock,
- the time taken from order to delivery and the cost of materials to be obtained from suppliers should be considered
- careful scheduling may be needed in Centres with a large number of students. It may be possible to permit several groups to do the work simultaneously or in quick succession, or it may be essential to re-order the scheme of work for different groups so that scarce resources can be used effectively.
- note must be taken of national or local health and safety regulations relating to laser light, high voltages, chemicals etc. There may also be regulations controlling the use of radioactive sources.

Once the scheme of work has been established, the next stage is to consider each practical activity or investigation. In an ideal course, each of the following stages would be gone through in developing each practical exercise in a course. This is not always realistically possible the first time through a course, and in such circumstances it is better to get some practical work done with students than to hold out for perfection before attempting anything. Obviously, all practical work should be subject to careful and rigorous risk assessment, no matter how provisional the rest of the supporting thinking and documentation may be.

- Decide on the aims of the work – the broad educational goals, in terms of the practical skills involved (e.g. evaluating procedures) and the key topic areas (e.g. deformation of solids)
- Consider the practical skills being developed. Reference should be made to the syllabus, which in the Practical Assessment section includes learning outcomes relating to practical skills. For instance, if the practical work intended is to be a planning exercise, which of the specific skills identified in the learning outcomes will be developed?
- With reference to the topics included, decide on the intended learning outcomes of the practical activity or investigation, again referring to the syllabus. For instance, which of the “waves” learning outcomes will be achieved? In some cases during the course, the material on which the practical is to be based may be unfamiliar, in which case there may be no topic-related intended learning outcomes. Thus, A2 contexts may be used for AS practicals, and topic areas not on the syllabus at all may be used for AS or A2 practicals.
- In addition, it is useful to assess any other context of the practical work investigation. For instance, is it intended as part of the introduction of a concept, or to support a theory, or to demonstrate a process?
- Produce a provisional lesson plan, allocating approximate times to introduction, student activities and summarising.

- Produce and trial a student worksheet. Published procedures or those produced by other teachers can be used. Alternatively produce your own. As a rule schedules produced by others need modifying to suit individual groups of students or the equipment available. It is helpful to ask students or another teacher to read work sheets before they are finalised as they can identify instructions that are ambiguous or that use inaccessible terminology.
- Refine the lesson plan in relation to the number of students for which the investigation is intended (whole class or a small group), the available equipment (does some have to be shared?) and materials. There are examples of lesson plans and student work sheets in Appendix 2.
- Carry out a detailed and careful risk assessment before any preparatory practical work is done, and certainly well before students do any of the practical work. You should consider
 - the likelihood that any foreseeable accident might occur.
 - the potential severity of the consequences of any such accident.
 - the means that can be taken to reduce the severity of the effect of any accident.
- Make an equipment and materials list. This should include
 - apparatus and materials (including quantities) per student or per group.
 - shared equipment per laboratory (e.g. sinks, top-pan balances).
 - the location of storage areas for equipment and materials.
- Set up and maintain a filing system where master copies of the work sheets, lesson plans and equipment lists can be stored. It is helpful to have these organised, or at least indexed, in both their syllabus context and skills developed.
- Once an investigation has been used by a group of students it should be evaluated in relation to intended outcomes and the lesson plan. It is important to obtain feedback from the students about their perception of the work. For example,
 - was the time allocation appropriate?
 - were the outcomes as expected?
 - did the students enjoy the work?
 - did the students understand the instructions?
 - was the point of the work clear to the students?

If necessary the work sheet and lesson plan should be revised.

Teaching AS skills

Teaching students to set up and manipulate apparatus

Some students will begin their AS course with very little experience of hands-on practical work, and consequently with limited knowledge of apparatus and limited skill in manipulating it. In this situation it is often sensible to begin a practical course with a circus of very short exercises designed solely to enable students to gain familiarity with common pieces of apparatus.

As an example, such a circus of short exercises might include practice in the use of retort stands, bosses and clamps. Clamping a half-metre rule so that it is exactly horizontal and a specified height above the bench is quite fiddly for inexperienced students and will teach them familiarity not only with the use of a stand, boss and clamp but also with the use of a set square and 30 cm rule to check that the rule is exactly horizontal. Setting up a simple pendulum of a specified length with the string clamped between two blocks of wood is similarly quite difficult and allows students an opportunity to think about why pendulums are set up in this way rather than, for example, by tying the string to the clamp.

Many students will need to be taught how to relate a circuit diagram, conventionally printed with straight lines and right angles, to the rather less tidy appearance of a real circuit. This can begin to be taught by asking students to draw a circuit diagram of a given series circuit, by tracing the wires from the positive to the negative terminal of the power supply. Students can then move on to more complex circuits with parallel branches. After this, students can be asked to use the same approach (of tracing the wires from the positive to the negative terminal of the power supply) to set up real circuits from circuit diagrams. In the initial stages it may be helpful to label circuit components and to provide a key to circuit symbols: students will learn to recognise both the components and the symbols as the course progresses, and after a while the labels can be dispensed with. The ability to connect circuits correctly from circuit diagrams will be needed (and hence reinforced) regularly during the course, particularly during the teaching of the whole of Section V of the syllabus, and the more often it is practised the better.

It is important that the students become confident with all the common apparatus that they may come across. During the course of the year they should all have experience of using as much of the common apparatus as listed in the syllabus and the CIE booklet *'Planning For Practical Science in Secondary Schools'* (June 2002). They need to be able to recognise different items of apparatus as well as learning to use them. In some cases it may be worth the students being encouraged to keep a skills and equipment log where they could record the apparatus and techniques that they have gained over the year.

Students' manipulative skills will develop over the course of the year. Some of this learning will take place in short exercises designed to introduce students to particular pieces of apparatus. Some of it (and much of the reinforcement) will take place while students are performing more involved experiments. The course should be designed to include some experiments which require some delicate manipulation and which may take some time to get to work successfully, such as the experiment to find the mass of a metre rule.

During the early part of the course some students will lack confidence and will need to be encouraged and supported. As the course continues and their experience grows, these students will become more confident and self reliant in practical situations.

Teaching students to make measurements and observations

Measurements are an integral part of Physics practical work. All of the practicals that are covered in the appendices to this booklet, and the questions in practical examination papers, will require multiple measurements to be made. In most situations, the measurements have to be made successfully before the student can move on to the next stage of the experiment.

At the beginning of the course, some students may have had little previous exposure to practical work and may lack confidence in making measurements and observations. Such students may be helped by a series of very short exercises designed simply to provide familiarity with the most common measuring devices. These exercises could form part of the same circus used to introduce them to other items of apparatus or to manipulative skills.

Familiarity with the use of measuring instruments can be gained both by short, highly-focussed exercises and by practice during longer, full-lesson practicals. Both approaches should be used. Every opportunity should be taken to give students practice in making measurements, even if this is part of a demonstration.

Students should be taught to look for situations in which the precision of measurements can be improved by measuring a multiple of the quantity. For example, the period of an oscillation can be more accurately measured by timing ten or twenty periods and then dividing by the number of periods. A similar principle can be applied to a wide variety of other measurements, for example measuring the thickness of twenty sheets of paper instead of just one, or the mass of fifty coins instead of just one. Students need to be encouraged to think about why this reduces the uncertainty in the measurement. They need to be given exercises in recognising such situations as well as being given practical work that requires them to use the technique.

The use of Vernier scales and micrometer screw gauges is something that particularly benefits from a dedicated activity to familiarise the students using them for the first time. As they will be used many times during subsequent practical sessions, this is time very well spent. There are also a number of internet-based activities that can be used to familiarise students with reading these scales.

The most common measuring instruments used in the AS level course will include millimetre scales on rules of various lengths, micrometer screw gauges, Vernier callipers, measuring cylinders, protractors, stopwatches, top-pan balances, newton-meters, thermometers, ammeters, voltmeters and cathode-ray oscilloscopes. Some students will also have access to light gates and electronic timing equipment.

It may be that the electrical meters generally used are all either digital or analogue, but students need to have some experience of reading from both types of scale. Some analogue meters have more than one scale printed on their faces, and students should be taught to recognise which scale to use.

Digital multimeters are both more versatile and considerably cheaper than the single-range meters available from specialised school laboratory equipment suppliers. Consequently many schools now only use digital multimeters. Students need to be taught how to select the appropriate range and the appropriate sockets on a digital multimeter, and to be given regular practice in their use.

Students are expected to be familiar with the precision of the measuring instrument used. This will need to be taught directly when each new measuring instrument is used for the first time. Each time the measuring instrument is used again, students should be encouraged to remember or identify the level of precision of the instrument. They should eventually know the levels of precision for most of the common measuring instruments and have the skills to be able to make a reasonable judgement when they forget or when they encounter a less familiar measuring instrument.

When considering the precision of a measuring instrument, students need to know when to interpolate between scale marks and when this is not appropriate. There are differing schools of thought on this question. At A/AS level, students are not expected to interpolate except when the smallest scale divisions are further apart than about 1 mm (which is not very common).

Students are expected to record their measurements to a degree of precision that is appropriate for the experiment. Sometimes this will be the same as the precision of the measuring instrument, and sometimes there will be reasons why the data is less precise than the measuring instrument used. (Examples include accurate stopwatches, where the reaction time of the operator is significant; or measurements of the amplitude of an oscillation, where the movement may be too rapid to be measured to the nearest millimetre). Students need to be trained to think about the appropriate degree of precision for their measurements, and this will not always be obvious to them. It will help them to learn if they are required to record their thought processes: if this is a consistent requirement it will eventually become second nature.

Where readings are repeated, the range of values obtained provides useful information about the uncertainty in the measurement. The average of the repeated readings should be calculated and used as the value of the measurement in subsequent stages of the experiment. The range in the value of the readings should be treated as twice the error in the measurement.

Students are also expected to know when to repeat readings and when not to. As with many other practical skills, this can be discussed initially and then reinforced by constant practice. It is not normally necessary to repeat all measurements, but it is usually good practice to repeat those that appear to be the largest sources of percentage error, or those where repeat readings can provide information about the uncertainty.

The terms precision, accuracy, error and uncertainty can cause much confusion in students' minds, and their meanings should be addressed directly early on in the course. Error and uncertainty are interchangeable terms in A/AS level, but the distinction between precision and accuracy is one that students are expected to understand.

Teaching students to record and present observations and data

Most of the observations and measurements that students make will be presented in tables of results and graphs. There are conventions for both tables and graphs that students have to learn and follow. They will find it easier to learn if the reasons behind the conventions are explained. Once it has been explained, constant reinforcement will make the conventions second nature.

When plotting tables of results, students need to:

- think ahead so that they have space for all the columns;
- show the quantity and unit in the column headings;
- be consistent in the degree of precision for each column of raw data;
- use the correct number of significant figures in calculated quantities.

Thinking ahead is not something that all students do naturally. To help them, they should be encouraged to draw out the framework of the table of results, with all the column headings in place, before they start to make the measurements and insert in the values.

For most experiments, two quantities are measured directly, and these will require a column each. Often there will be a need to repeat readings for one of these quantities: this will add to the number of columns. In addition, calculated quantities will often be needed for plotting on the graph, in which case each calculated quantity will require a column. A typical blank table of results is shown below. In this table, l and t are measured directly; readings of t have been repeated (to give t_1 , t_2 and the average value t_{AV}); and the graph is one of l against T^2 (where $t = 10T$) so a column has been provided for the calculated quantity T^2 .

l/cm	t_1/s	t_2/s	t_{AV}/s	T^2/s^2

Students should be discouraged from recording their data initially on a rough piece of paper and transferring it later onto a ‘neat’ copy of the table of results, because this introduces copying errors, wastes time, and runs the risk that the rough piece of paper will be lost.

It is good practice to carry out just one “dry run” of collecting a set of readings before actually beginning work. The advantage of this is that it will give students a feel for the problems and will allow them to make an informed decision about which readings, if any, should be repeated.

The column headings should show the quantity and the unit, as in the example above. These should normally be separated by a solidus (slash). No units should be shown beside the values in the body of the table.

Within each column of raw data, the degree of precision should be consistent. For example, if l/cm in the table above could be measured to the nearest 1 mm, then all the values in the column should be given to the nearest millimetre. This may mean that the number of significant figure is not consistent: the values might, for example, range from 68.4 cm to 8.7 cm.

In calculated quantities, the number of significant figures should be appropriate for each value, given the number of significant figures in the raw data from which they are calculated. Since the number of significant figures may vary within a column of raw data, it follows that it may also vary within a column of calculated data.

Most physics practical work requires that data is displayed on a graph, and the graph is usually (although not always) a straight line graph. Students need to know how to plot graphs correctly. However, if they are to be successful at evaluation and planning, they also need to have a clear understanding of why graphs are plotted. This may be taught by providing some data and facilitating a discussion among the students.

For example, this could be taught using the example of an experiment to determine the spring constant k of a spring from the equation $F = kx$, where F is the force and x is the extension.

Start with a single reading of F and a single reading of x , and calculate k . Ask whether that is enough data, and establish that more data will minimise the effects of any aberrant readings.

Then provide several sets of readings, calculate k for each set separately, and find the mean value of k . Discuss whether this is a good way to find k . Establish that the aberrant reading, if there is one, has still contributed to the answer. Think about the limit of proportionality and how you would know whether or not it has been exceeded.

Plot a graph of F (y -axis) against x (x -axis). Find the gradient and show that it should be equal to k . Point out how easy it is to spot (and discount) any data that is aberrant or beyond the elastic limit. Discuss how the data would have looked on the graph (and how the gradient would have been affected) if there had been a systematic error (for example, if the mass hanger’s mass had been 120 g when it should have been 100 g).

Conclude that plotting a graph and taking the gradient is a way of:

- averaging the data so that the effects of random errors are minimised;
- identifying aberrant points (which should be investigated further);
- eliminating some systematic errors;
- checking that the shape of the graph is as it should be.

The data for this lesson could be collected from real apparatus in a demonstration, with the whole class processing and discussing the data. If the mass of the mass hanger is adjusted to produce a systematic error in the data, so much the better. There is no need to introduce aberrant readings or to exceed the elastic limit of the spring: it is enough that these points can be checked on the graph.

There are a number of conventions to be followed in the plotting of graphs, and students need to learn these. These include:

- labelling of axes (these should be clearly labelled in the same way as the column headings in the table of results, with the quantity and the unit, and the values on the scale should be marked at frequent intervals);
- choosing scales that are easy to read (so awkward ratios such as 3, 5, 6, 7 or 9 squares per unit should be avoided);
- choosing scales that spread out the data points (i.e. so that the data is spread across at least half of the width of the graph paper and across at least half of the height. This may mean that a false origin has to be used, i.e. the point (0,0) is not shown on the page);
- plotting all of the data accurately;
- drawing a best-fit straight line through the points (when the points lie in a straight line) (there should be the same number of points above and below the line, and in each half of the line there should be the same number of points above it and below it);
- being neat (small crosses drawn with a sharp pencil for the data points; a thin best-fit line drawn with a sharp pencil and a clear plastic ruler: neat work allows the accuracy of the work to be checked);
- reviewing the data (the graph allows the data to be reviewed to see whether any of the points are anomalous and whether the expected trend is observed. Anomalous readings should always be checked, to see if there is an error in the plotting or in the readings).

The skills of presenting data in tables and on graphs should be seen as a developing set and something that students will improve with as they gain confidence and experience during the course. This will mean trying to choose practicals and activities that have a relatively contained, uncomplicated set of results in the early stages of the course and then working up to more complicated sets. Many students find that having a brief checklist helps them while they are still struggling to learn how to draw graphs, and the checklist also serves as a useful revision tool later on.

Teaching students to analyse data and draw conclusions

The analysis of data in AS level practical work can take a variety of forms, including:

- estimating uncertainties in measured quantities and converting between actual and percentage uncertainties;
- finding the peak value of a curve or reading specific values from a graph;

- finding the gradient and y -intercept of a graph;
- relating a straight line graph to a formula in the form $y = mx + c$ to enable the values of constants to be determined;
- relating a graph or a set of data to a formula to conclude whether the data supports or contradicts the formula;
- using data to suggest whether or not two quantities are proportional;
- using data to formulate a hypothesis.

Students will need to be taught specifically and directly how to find the gradient and y -intercept of a graph. Whenever they calculate gradients, students should be encouraged to draw a triangle on their graph from which they can read values of Δy and Δx (and which you can use when checking through their work). They should be asked to think about the precision with which they can read Δy and Δx if the triangle is very small and very large, and should be led to the conclusion that the triangle should be as large as possible. It is the usual practice in examinations to require that the triangle spans at least half of the length of the line drawn, and this point can be emphasised to students. The most common mistakes that students make when calculating gradients are:

- using a small triangle;
- drawing the triangle between two data points instead of two points on the line of best fit;
- calculating $\Delta x / \Delta y$ instead of $\Delta y / \Delta x$.

Students need to be told what the term “ y -intercept” means. Once they know this, they do not usually have great difficulty in reading the y -intercept directly from a graph. However, they do find it more difficult to determine the y -intercept where a false origin has been used or where the line of best fit goes through the top or bottom of the page before it reaches the y -axis. They need to be shown how to substitute the co-ordinates of one point (x , y) on their line, plus their value of the gradient m , into the equation $y = mx + c$ in order to find the value of the y -intercept c . It is a common mistake to use one of the data points instead of the co-ordinates of a point on the line in this substitution, and students should be shown that this gives an incorrect answer.

Technically, the gradient and y -intercept on a graph are numbers and have no unit. Students should not, therefore, be asked to give the units. However, the gradient and y -intercept may be *numerically* equal to constants which do have units. Students need to know that, in such cases, the units should be derived from the labelling of the axes on the graph.

The techniques for finding the gradient and y -intercept need to be explained to students first in a classroom setting, and then reinforced with a series of pen and paper exercises using sets of data provided. After this, they should be reinforced by providing practical work that includes the use of graphs.

Students often find it difficult to rearrange a given formula into the form $y = mx + c$, and to relate this to the graph that they have plotted. For example, in a falling ball experiment, they might be told that $g = 2h/t^2$ and asked to find the value of g from a graph of h (y -axis) against t^2 (x -axis). They need to be shown that, with h on the y -axis and t^2 on the x -axis, the formula has to be rearranged into the form $h = mt^2 + c$. From this, they should be able to reach the equation $h = \frac{1}{2}gt^2$ and hence realise that the gradient is numerically equal to $\frac{1}{2}g$ and that the y -intercept should be zero. After they have worked through an example like this in open class discussion, they should then be given several similar examples to work on to reinforce the skill. After this they should be equipped to use this skill when they encounter it in practical work.

The ability to manipulate formulae and to relate them to graphs is an important foundation stone for some of the planning and data analysis skills that students will encounter in their A2 course. You may need to check that students continue to practice this skill, and to provide some remedial exercises if necessary.

Students will need to be shown how to convert between percentage errors and actual errors, and opportunities should be found periodically to put this into practice in practical work. This can be done, for example, by asking them to consider which of their measurements has the largest percentage error. Similar questions can be included in the worksheets for most experiments. Identifying significant sources of error is an important skill both because it informs students' decisions about which readings should be repeated and because it is a useful first step in the evaluation of the experimental procedures.

Teaching students to evaluate procedures

Students need to have a good understanding of experimental procedures before they can begin to be confident in evaluation. This understanding should include both a familiarity with a range of practical techniques and apparatus and a good grasp of the reasons why experimental procedures are carried out in particular ways. For this reason, evaluation procedures are best introduced in the second half of the AS year, after the other AS skills have been taught and practised.

The evaluation of very precise well-designed experiments can be difficult for students. With no significant sources of error and no major faults in the procedures used, students find it difficult to know what to write. When teaching evaluation skills, it is kinder to provide experiments which include significant sources of error, weaknesses in the method used to analyse the data, and plenty of scope for improvement.

It is sometimes suggested that students can evaluate experimental procedures without having carried them out. This is nearly always an unreasonable expectation. Some of the evaluation usually involves particularly difficult measurements, such as a length that is not easily accessible with a rule. Unless students have grappled with taking the measurement, they will have great difficulty in visualising the problems. Students need to do an experiment before they evaluate it.

Initially, students can be asked to estimate the actual error in the measurements they make and to convert this into a percentage error. In this way they can be asked, as a matter of routine, to identify the largest sources of error in the experiment. They should also be taught the difference between random and systematic errors and encouraged to check for systematic errors in their measurements.

From this starting point, students can begin to use checklists to help them to think about the limitations in an experiment. The checklist could include the following questions.

- Apart from the variables being measured, was there any other factor that might have affected the results?
- Which measurements were difficult to make?
- What were the largest sources of error?
- Were there any systematic errors?
- Was enough data collected?
- Was the range and distribution of the data points appropriate?
- Was a graph of the data plotted?

In each case, students should be asked not only to identify the limitations, but to suggest a way to improve the experiment. The improvements could range from suggesting the control

of variables to the use of more appropriate measuring instruments and to making measurements in a different way.

The checklist should be first introduced after the whole class has done the same experiment, even if this is a very short exercise. Responses to the checklist can be collected in a brainstorming session and then discussed so that students begin to get a feel for the sorts of suggestions that are appropriate to an evaluation. After this, students should be given regular opportunities to practise and develop their skills.

The practical work conducted after this point should not consist entirely of poorly-designed experiments which students can evaluate. Well-designed and precise experiments need to be interspersed with evaluation exercises so that students are given constant reminders of good experimental practice.

In their evaluations of the procedures followed in experiments that the students have carried out for themselves, repeating readings should not be regarded as an appropriate response. The reason is that, if it was appropriate to repeat readings, then this should have been done when the experiment was carried out. In the context of a demonstration, however, it might be necessary to accept this point!

As a rough rule of thumb, six data points is usually sufficient to provide a good straight line graph, but more data would nearly always improve the reliability of an experiment. When designing a practical for students to evaluate, it is a good idea to ask them to collect just two or three sets of data, and to omit the plotting of a graph. This provides opportunities for students to identify limitations and to suggest improvements. The checklist should help students to spot these particular weaknesses.

Whenever a class experiment has been carried out, it can be of great value for the whole class to discuss the limitations and sources of error. As well as being a useful tool to encourage class discussion, it creates a very simplistic 'peer review' model from which parallels can be drawn with professional scientific enquiry.

Designing a practical course for the AS year

This booklet is designed as a guide to help and support teachers in the delivery of the course. It does not provide a complete course on its own and does not offer full coverage of every aspect of the syllabus in detail. Instead, it is intended to help equip teachers to plan and deliver a full, coherent course. It is intended to complement the resources and experience already existing in the Centre.

Appendix 1 of this booklet provides a list of suggested practical activities that could be used to help deliver a Physics practical course at AS level. They are only suggestions: some of them may not be suitable for your centre and so you may need to adapt them or select alternatives.

The activities in Appendix 1 are listed in syllabus order, that is, in the order in which the subject content (not the practical skills) are listed in the syllabus. The actual order in which these practical activities are carried out will depend largely on the sequence in which the theory is taught, so that theory and practical work support each other in the learning process. When considering an order for the practical activities, you will also have to consider the sequence in which you are introducing new practical skills and techniques. Some of the activities will need careful adaptation to ensure that they only require the skills that have already been introduced and that they include the practical skills that you want to reinforce at that time.

For each practical activity, it is suggested that the following documents are produced:

- a student worksheet (to tell the student what to do);
- teaching notes (specifying the objectives of the activity);
- technical notes (specifying the apparatus, materials and facilities required).

As examples of how practical activities can be worked up in this way, Appendix 2 takes ten of the practicals from Appendix 1 and provides all three documents for each. The intention of Appendix 2 is that it should demonstrate to teachers how practical activities may be worked up and equip them to do the same for the whole of their AS level practical course.

Planning the course

The skills and techniques required of students are clearly laid out in the syllabus. When putting together a practical course, the syllabus should be used as a guide to ensure that the skills and techniques are all covered on at least one occasion (and hopefully more often).

When planning and preparing a course of lessons for the year, it is important to try and make sure that relevant practical activities are connected to the theory lessons and not just seen as an add-on. Practical work has a much greater strength if it is seen to complement and support the theoretical work covered in other lessons. Some practical skills may be introduced in one lesson and then developed or used in another lesson, building into a sequence. This helps to provide continuity for the students and to reinforce their learning.

By planning in advance it will be possible to select activities that run parallel with the content from the syllabus being delivered as well as providing a variety of different types of lesson. This will help to maintain students' interest and motivation.

When a practical activity requires a new skill, technique or piece of equipment, time needs to be set aside for this. This may mean that an extra activity needs to be included at the start of the lesson to prepare the students in advance. Alternatively it may be more appropriate to allow for extra time and support during that particular activity.

Using past exam papers

Past papers are available from CIE and can form a useful part of final exam preparation. They often touch on content from the syllabus but do not always deal with it as directly as the examples in Appendix 2. They are therefore of limited use as practicals intended to complement the teaching of theory. In addition, they usually require a high degree of familiarity with the full range of practical skills. As such, if students are not totally confident with their skills and knowledge they will be unlikely to be able to gain the full benefit from them.

Past exam papers should be seen less as a teaching tool but more as a valuable resource to be used towards the end of the course as part of a structured revision program. They have a role to play in the reinforcement of the practical skills that have been covered and in the final preparation for the examination.

Planning lessons and teaching the course

In the teaching notes section of each practical activity in Appendix 2, there are detailed notes including clearly highlighted 'key learning objectives'. It is important that these objectives are stressed when the activity is being introduced and described to the students. Many students can carry out practical activities without fully understanding what they are doing and why they are doing it, and this inhibits their ability to learn from the experience. It is usually worth explicitly stating the key learning objectives to the students so that they have a clear focus for the lesson.

Although students will be involved in practical activity for most of the lesson, some lesson time should be spent on ensuring that each activity is properly introduced. The way an individual lesson is structured is very much up to the individual teacher but below is one possible approach to teaching practical activities.

Introduction (10 mins)

A teacher-led oral presentation which includes:

- An explanation of the activity that is to be carried out.
- A recap or explanation of the theory that relates to the practical. In many cases this will have been covered in more detail in a previous lesson.
- A description (and possibly a demonstration) of any equipment that is to be used or is needed in the practical. It is easy to make assumptions about what the students are confident with and this provides an opportunity to check before they start. If a new piece of equipment is to be used then the skills needed to use it must be directly taught. This may be done at this point but in some cases it is better to have provided a dedicated session at an earlier time.
- Safety. This should be raised before every single practical regardless of the risk. Students can be asked to make the risk assessment themselves and to make suggestions as to appropriate precautions although each practical must have been risk assessed by a teacher beforehand.

Preparation (5 – 10 mins)

Students should be encouraged to prepare before starting to take readings. As well as setting up the apparatus, they should also be encouraged to make one 'dry run' of a set of readings. They should consider the range of readings to be taken and whether repeat readings are needed. They should prepare the outlines of their tables of results.

Main activity (35 – 60 mins)

Each of the practical activities will take different amounts of time depending upon the students involved and the nature of the task. During this time some groups may well need support and help.

Plenary (5 – 10 mins):

A teacher-led session where the main threads of the practical are brought back together. Some of the areas covered could include:

- A recap of the theory that underlies the activity and a reminder to cross-reference the practical work and the theory notes.
- A discussion of the practical skills and any particular equipment or techniques that were needed.
- A discussion of any limitations, errors or problems involved in the activity and ways in which these could be dealt with.
- A reminder of the expectations of the written work that will follow (which should be included in the student worksheets).

Planning for a circus

In many Centres, practical activities may be carried out as part of a circus. In this case it is not possible for an introduction to the activities to be held as a teacher-led plenary session at the start of each lesson, because there are too many activities taking place. However, the introduction of each activity is important and should not be lost: it helps the students to understand both what they are doing and why they are doing it. One possible solution to this is to hold a 'circus introduction session'.

For the first session of the circus, set up the laboratory so all the equipment for each of the activities is visible. Take the whole class round the laboratory introducing each experiment, using the introduction section above as a guide. Although this may take quite some time, this is a worthwhile thing to do and will hopefully allow each subsequent practical session to run more smoothly. It will give students a clearer idea of what they are required to do.

A possible alternative to this would be to run the first session without introducing the experiments. Give the students a very quick run-through and then issue the student worksheets. Let students know that, at the beginning of the next session, they will need to describe the key points to the rest of the class. Begin the next session with each group introducing to the rest of the class the activity they have done. If this approach is taken then this can act as a good way to get the students to develop their communication skills.

Appendix 1: Possible AS practical activities

The table below lists a series of practical activities that can be delivered to both support the theory and to develop the students' practical skills. The activities are mapped against the learning outcomes in the theory sections in the syllabus and are listed in syllabus order.

Each practical activity should also be mapped against the practical skills required, partly to ensure that the skills and equipment are introduced at the correct points and partly to ensure that all skills are covered during the course. Many of the practical activities could be conducted in different ways to give emphasis to different skills, and therefore the mapping must be done when the details of the practical are worked out (i.e. when the student worksheets, teaching notes and technical notes are produced).

Suggestions have been made whether something is suitable as a demonstration or practical. In almost all cases it is possible for students to carry out experiments listed as demonstrations, although the experiments may need to be set up and tested beforehand.

Practical Name	Description / comments	Suitability for practical or demonstration	Link to syllabus learning outcomes
Terminal velocity	Detailed in Appendix 2.	Practical	3(b), 3(d), 3(j), 5(c)
Measuring speed and acceleration	Using ticker timers or data-logging equipment, and trolleys or a linear air track, the motion of objects moving at constant speed or with constant acceleration can be analysed. The experiments should be set up so that students can collect data that can be used to plot motion graphs which they can analyse.	Practical	3(b), 3(d), 3(e), 3(g)
Acceleration down a slope	Detailed in Appendix 2.	Practical	3(g)

Practical Name	Description / comments	Suitability for practical or demonstration	Link to syllabus learning outcomes
Measurement of g with falling object	<p>A millisecond timer is connected to two switches, as the ball is dropped the timer starts. When it has fallen a certain distance it triggers the second switch and stops the timer. Using Newton's laws g can be calculated.</p> <p>Alternatively this experiment could be carried out with data-logging equipment or ticker timers.</p>	Practical or demonstration	3(g), 3(i)
Force, mass and acceleration	<p>An object is accelerated with a known force. The relationship between force and acceleration can then be analysed graphically and the mass of the system found.</p> <p>This is often done by accelerating trolleys along a bench with a known weight on the end of a pulley hanging over the edge. The acceleration is recorded (directly or indirectly) by data loggers or a ticker timer for different accelerating forces.</p> <p>Elastic bands can be used to apply the force but this will only allow the identification of a linear relationship between force and acceleration.</p>	Practical	4(a), 4(b), 4(f)

Practical Name	Description / comments	Suitability for practical or demonstration	Link to syllabus learning outcomes
Conservation of momentum	<p>An experiment to investigate the law of conservation of momentum.</p> <p>This is commonly done with two mechanics trolleys or two vehicles on a linear air track (although freely running toy cars can be used). Both their velocities are measured by ticker timer, data logger or other method before and after any collision. Various collisions are carried out and each time the momentum before and after the collision can be calculated from the masses and velocities and from this the law can be verified. Investigations into elastic and inelastic collisions can also be carried out.</p>	Practical	4(h), 4(d), 4(i), 4(j)
Weight and upthrust	<p>A known mass is hung on the end of a newton meter, this is then lowered into a beaker of water (or other fluid) and the changes in the reading on the newton meter are recorded as the object is immersed.</p> <p>The experiment can be extended by placing the whole experiment on a top-pan balance and observing the change in reading on that at the same time.</p>	Practical or demonstration	5(b)
Triangle of forces board	Detailed in Appendix 2.	Practical	5(d)
Finding the mass of a metre rule using the principle of moments	Detailed in Appendix 2.	Practical	5(i), 5(e)

Practical Name	Description / comments	Suitability for practical or demonstration	Link to syllabus learning outcomes
Finding the densities of different materials	Detailed in Appendix 2.	Practical	9(a)
Structure of metals	<p>The crystalline nature of the structure of metals can be shown by looking at prepared samples under a microscope.</p> <p>Alternatively if a galvanized metal bucket or similar is available then it is often possible to see the crystal grains clearly with the naked eye. Sometimes the surface needs a light clean in order to show the grains clearly.</p>	Demonstration	9(e)
Changes of state (boiling)	<p>If water is heated with a constant source of energy input (electrical heater or Bunsen flame) and the temperature is recorded it is possible to demonstrate graphically that at the change in state from liquid to gas there is no change in temperature whilst energy is still being supplied to the system. The water needs to be constantly stirred and care needs to be taken that the container does not boil dry.</p> <p>Data-logging equipment could also be used to investigate evaporation and the energy changes involved.</p>	Practical or demonstration	9(i)
Elasticity and springs	Detailed in Appendix 2.	Practical	10(b), 10(f)
Finding the Young modulus of a wire	Detailed in Appendix 2.	Practical	10(c), 10(d)

Practical Name	Description / comments	Suitability for practical or demonstration	Link to syllabus learning outcomes
Material failure	<p>Samples of various materials can be examined under a microscope in order to illustrate their structures. Students could discuss whether they felt that the failure was brittle or ductile.</p> <p>Samples could include the wire used in the Young modulus experiment, a piece of acrylic that has been snapped, a piece of broken glass or spaghetti.</p>	Practical or demonstration	10(g)
Measuring the frequency of a sound in air	<p>A loudspeaker is connected to an audio-frequency signal generator and a note is produced. A microphone is connected to an oscilloscope and it is adjusted until a stable trace is shown. By adjusting the time base and x-shift knobs to get a good trace, a value for frequency can be calculated.</p> <p>Knowing the speed of sound in air will allow a value of wavelength to be calculated.</p>	Demonstration	15(d), 15(j)

Practical Name	Description / comments	Suitability for practical or demonstration	Link to syllabus learning outcomes
Measurement of the speed of sound in air using a dual-beam oscilloscope	<p>A microphone is connected to a dual-beam oscilloscope. The other connection of the oscilloscope is connected to an audio-frequency signal generator and loudspeaker. Slowly move the microphone and observe the phase differences between the two traces. Measure the distance the microphone moves as the traces on the oscilloscope move from one in-phase position to the next in-phase position. This distance is the wavelength of the sound.</p> <p>Determine the frequency of the sound from the oscilloscope traces and use the equation $v = f\lambda$ to calculate the speed of sound.</p>	Practical	15(d), 15(j), 15(b)
The relationship between sound intensity and distance	<p>A loudspeaker is connected to an audio-frequency signal generator and a note is produced. A microphone is connected to an oscilloscope and it is adjusted until a stable trace is shown. By changing the distance between the microphone and the loudspeaker, the amplitude of the trace on the oscilloscope can be related to the sound amplitude and hence to intensity.</p> <p>Depending on the equipment and the acoustics this may not deliver high quality results. The inverse square law is outside the syllabus but the experiment can provide a useful open-ended investigation or an opportunity for evaluation.</p>	Practical or demonstration	15(f)

Practical Name	Description / comments	Suitability for practical or demonstration	Link to syllabus learning outcomes
Measurement of the speed of sound in air using stationary waves	<p>A glass or plastic tube that is open at both ends with a half-metre rule attached to it is placed inside a larger container filled with water. A tuning fork of known frequency is struck and held just above the tube. The tube is then raised until the sound reaches a maximum loudness. The length of tube above water level is measured.</p> <p>This is then repeated for different tuning forks and a data set for frequency f and length l of tube is recorded. Analysis of the standing wave gives $\lambda = 4l$ and from this and $v = f\lambda$ the speed of sound can be calculated.</p>	Practical	15(k), 15(d), 16(b)
Young's slits	<p>A laser beam is passed through a double slit (typically less than $\frac{1}{2}$ mm apart) and onto a screen several metres away. From measurements of the interference pattern, the wavelength of light may be calculated (if the slit separation is known) or the slit separation may be calculated (if the wavelength is known).</p> <p>It is possible to perform this experiment with a more conventional light source (ideally over 40W), lenses and slits. If this is the case then the distance to the screen is likely to need to be reduced in order to gain a visible pattern.</p>	Practical or demonstration	16(g), 16(h), 16(i), 16(e)
Diffraction grating	A similar experiment to the Young's slits experiment can be carried out with a diffraction grating.	Practical or demonstration	16(j), 16(i), 16(e)

Practical Name	Description / comments	Suitability for practical or demonstration	Link to syllabus learning outcomes
Using an oscilloscope as a voltmeter	<p>A very quick demonstration will involve connecting a cell or any d.c. supply to an oscilloscope and adjusting the controls to gain and measure a reading. Depending upon the oscilloscope it may be advisable to turn the time base off in order to make this demonstration more clear.</p> <p>a.c. power supplies can also be connected (with the time base on). This provides an excellent introduction to the oscilloscope and explaining what the controls do and how they can be adjusted.</p>	Demonstration	19(d)
Measuring the resistivity of a wire	Detailed in Appendix 2.	Practical	19(h), 19(l)
Behaviour of a thermistor	<p>A thermistor is connected to a digital multimeter able to read the resistance directly and is then placed in a beaker of water. The water is heated and the temperature measured. A set of temperature and resistance readings can be collected and a calibration graph for the thermistor plotted. The range of the data can be extended if ice is used.</p> <p>This can give students experience of selecting the appropriate scale on a multimeter as well as an introduction to calibration curves.</p> <p>The experiment could also be done using a battery or power supply and an ammeter or voltmeter (either or both of which could be digital multimeters).</p>	Practical	19(j)

Practical Name	Description / comments	Suitability for practical or demonstration	Link to syllabus learning outcomes
Ohm's law	<p>A simple circuit with a variable d.c. power supply, an ammeter, a voltmeter and a resistor can be used to investigate Ohm's law experimentally and to determine the resistance. Readings should be taken for positive and negative values of p.d. In most cases this will just mean swapping the connectors of the resistor supply around.</p> <p>If standard meters are used, it is important to choose the resistor well in order to get a good set of readings. This is less of an issue if digital multimeters are used. Safety note: the resistor can get very hot, particularly if the resistance is low. A milliammeter and a 1 kΩ resistor will be suitable.</p>	Practical	19(k), 19(h)
<i>I</i> - <i>V</i> characteristics of a filament lamp and a semiconductor diode	<p>A simple circuit with a variable d.c. power supply, an ammeter, a voltmeter and a filament lamp can be used to plot the <i>I</i>-<i>V</i> characteristics of a filament lamp. The experiment can then be repeated using a semiconductor diode.</p> <p>The power consumption of each component at a specified voltage can be determined from the graphs.</p>	Practical	19(i), 19(f)

Practical Name	Description / comments	Suitability for practical or demonstration	Link to syllabus learning outcomes
Internal resistance of a dry cell	<p>A simple circuit with a voltmeter, an ammeter, a dry cell and a variable resistor (suggested 10Ω to 100Ω) is set up. The resistance is varied and a set of readings for the p.d. across the cell and current in the circuit is collected. From this data the internal resistance can be determined from a graph of p.d. against current.</p> <p>The variable resistor and the internal resistance need to be of comparable resistance and it may be necessary to connect a fixed resistor in series with the dry cell in order to simulate a larger internal resistance than is actually present.</p>	Practical	19(o)
Internal resistance of a potato cell	<p>A similar experiment to the internal resistance of a dry cell can be carried out using a potato cell instead of the dry cell. The potato cell is constructed from a potato with zinc and copper sheet electrodes inserted into it. Similar cells can be constructed from most types of fruit or vegetable provided that it is moist inside.</p>	Practical	19(o)

Practical Name	Description / comments	Suitability for practical or demonstration	Link to syllabus learning outcomes
LDR and light intensity	<p>An LDR is connected to a battery or power supply, an ammeter and a voltmeter so that its resistance can be calculated. The LDR is placed on the zero end of a metre rule which is pushed inside a thick cardboard tube with black paper around it. At the other end of the tube is a lamp. The LDR is moved towards and away from the lamp and resistance and distance are recorded.</p> <p>If the LDR has been calibrated beforehand (or if the manufacturer provides calibration details) then the variation of light intensity with distance can be investigated.</p>	Practical	20(b), 20(k)
Potential divider	Detailed in Appendix 2.	Practical	20(j)
Measuring g using a pendulum	Detailed in Appendix 2.	Practical	-

Appendix 2: Examples of AS practicals

Each of the ten practical activities in this appendix consists of a student worksheet, teaching notes and technical notes. These have been printed on separate pages for ease of photocopying: teachers are welcome to photocopy these pages for use within their own schools.

It is assumed that students will, as a matter of course, be required to write a brief account with a diagram of the experimental arrangement. The worksheets do not make this requirement explicit.

In all cases, the practical activities could be adapted to allow for the fact that different schools have different apparatus available. Most may also be adapted to change the practical skills that are given emphasis. The intention, in this appendix, is to illustrate how an idea for a practical activity may be worked up into student worksheets, teaching notes and technical notes.

Terminal Velocity

Student Worksheet

In this experiment you will be making measurements of a ball bearing falling through oil in order to analyse its motion.

Theory

A displacement-time graph can be used to analyse the motion of an object.

- If the best fit line of the graph is a straight line then this means that the object is travelling at constant velocity.
- The steeper the gradient of the line, the greater the velocity of the object.
- The gradient is equal to the numerical value of the velocity of the object.

When an object is falling through a fluid such as air or water, there is a viscous force opposing the motion. The resistive force increases as its velocity increases. Eventually the resistive force becomes equal to the downwards force (weight) and so the resultant force on the object is zero. At this point the object no longer accelerates and continues at a constant velocity, known as a terminal velocity.

In this experiment you will record the time a ball bearing takes to fall different distances through oil. From a displacement-time graph of this motion you will determine whether the ball bearing reaches a terminal velocity.

Making measurements and observations

- 1 Fill the measuring cylinder with oil. You will need to decide on 10 distance markers down the side of the cylinder, and these markers must be at known distances down from the surface of the oil. You should use the volume divisions on the measuring cylinder for these markers, but you will need to measure their distance below the oil surface accurately.
- 2 Hold a ball bearing so that the bottom of it just touches the surface of the oil. Release the ball and at the same time start the stopwatch. When the ball reaches the first marker, stop the stopwatch and record the time. Make sure that your eye is at the same level as the marker to avoid parallax error.
- 3 Use the magnet to remove the ball from the measuring cylinder.
- 4 Repeat **2** but this time measure the time taken to reach the second marker.
- 5 Continue taking results for the time it takes the ball to fall different distances until a full set of results is obtained. You may wish to repeat your results in order to improve their quality.

Recording and presenting your data

- 1 Your table of results should include displacement (i.e. the distance from the surface of the oil) and the time taken by the ball. The displacement should be recorded in metres. If you have repeated the time readings, you should include the individual readings and the average.
- 2 Draw a graph of displacement (y -axis) against time (x -axis).

Analysing your data

- 1 Making reference to the graph, describe how the velocity of the ball changes as it falls. Relate the changes in velocity to the forces involved. Where possible, include in your account any numerical values that are relevant.
- 2 Discuss whether the ball has reached a terminal velocity. You will need to explain your answer with reference to the graph.
- 3 If the ball did reach a terminal velocity, calculate the value of the terminal velocity from the graph. Show your working.

Evaluation

- 1 State one assumption that was made in the way that this experiment was designed. Discuss whether this assumption was justified.

Terminal Velocity

Teaching Notes

Link to theory

- 3(b) *use graphical methods to represent displacement, speed, velocity and acceleration.*
 3(d) *use the slope of a displacement-time graph to find the velocity*
 3(j) *describe qualitatively the motion of bodies falling in a uniform gravitational field with air resistance*
 5(c) *show a qualitative understanding of frictional forces and viscous forces including air resistance*

The experiment also overlaps partly with, or could be used to lead into some of, the content of 3(a), 3(c), 3(e) and 3(i).

Key learning objectives

- To provide an opportunity for graphical analysis of displacement-time graph for a moving object.
- To develop the technique of using the gradient of a graph in analysis.
- To provide experimental experience of an object falling at terminal velocity (usually difficult under classroom conditions).

Notes

This experiment looks at accuracy in a slightly different way. In order to get a full set of results for the motion of the ball, multiple experiments will be carried out. These will enable a displacement-time graph to be plotted for a ball falling through oil, the assumption being that every ball will behave in the same way. The assumption that the behaviour of the ball will be the same every time needs to be discussed and challenged as this is the basis for the whole experiment. Hopefully students will see that the assumption is justified and will appreciate that the main source of error lies in starting and stopping the stopwatch at the correct points rather than the behaviour of the ball itself.

Some students may need support when attempting to calculate the velocity values from the graph as they may lack confidence. It is very important that they develop this skill as this will be needed many times during the course. Some will try to calculate velocities from the numerical data itself: they should be made to make velocity calculations from the graph.

Expected results

The ball should reach a terminal velocity reasonably quickly.

Possible extension work

Students could investigate balls of different diameters or balls of different masses but the same diameter. If a supply of different grades or thicknesses of oils were available then these could also be looked at.

It is possible to extend this work much further in order to provide an experimental look at Stokes' law. This may well be more suited to an A2 practical as the analysis becomes more complicated.

Terminal Velocity

Technical Notes

Apparatus requirements

- 1 Large measuring cylinder**, 500 ml or 1000 ml. If one is not available a piece of clear plastic tubing can be used but it must be sealed at one end (so that the oil cannot leak out) and it must be marked with ten equally spaced marks down its length.
- 2 Engine Oil.** The quantity should be enough to almost completely fill the measuring cylinder. Most car engine oils will be suitable although multigrade oil is most widely available. The oil must not be so thick that the ball moves very slowly (i.e. over 20 seconds to make it to the bottom) or so dark that the ball cannot be easily seen. If engine oil is not available then it may be possible to use other viscous liquids such as cooking oil. What is important is that the ball reaches a terminal velocity relatively quickly.
- 3 Steel Ball Bearing.**
- 4 Magnet.** This will be used to remove the ball bearing from the oil.
- 5 Paper towels.** To dry the oil from the ball bearings when they are removed from the oil, and to clear up any spillages.
- 6 Stopwatch** reading to 0.1s or better.
- 7 Metre rule.**

Notes

Whilst it is very unlikely that any source of engine oil will be flammable at room temperature it is vital that a full risk assessment is carried out, referencing the hazard information that is provided with the oil. The risk of slipping if the oil is spilled must also be considered.

Acceleration down a Slope

Student Worksheet

In this experiment you will make measurements of a ball rolling down a slope in order to calculate its acceleration.

Theory

If an object rolls from rest down a slope, then it is possible to calculate the acceleration of the object from the distance it has travelled and the time it takes.

The equations for uniformly accelerated motion state that

$$s = ut + \frac{1}{2} at^2.$$

where a is the acceleration, u is the initial velocity, s is the distance travelled and t is the time taken.

If the ball starts from rest then $u = 0$ and the equation can be re-written as

$$s = \frac{1}{2} at^2.$$

So, by measuring the time taken for an object to move a known distance down a slope, it is possible to measure its acceleration.

By comparing this to the equation for a straight line we can see that if a graph of s (y -axis), is plotted against t^2 (x axis) then this should be a straight line of gradient $\frac{1}{2} a$ that passes through the origin.

Making measurements and observations

- 1 Set up the slope at an angle so that it takes at least two seconds for the object to roll down the complete length.
- 2 On the slope, mark six points at different distances from the top end of the slope. The lowest point should be at least 0.75 m from the top end of the slope and the intervals between the points should be between 0.1 m and 0.2 m.
- 3 Measure the time t taken for the object to roll from rest from the top of the slope through a distance s to one of the marks on the slope. The time t should be measured at least three times. You will need to take steps to ensure that your results are as accurate as possible.
- 4 Repeat for different distances s , recording the values of s and t .

Recording and presenting your data

- 1 Your table of results should include the distance s recorded in metres and the time t recorded in seconds. As you have repeated the time readings, you should include the individual readings and the average value in your table. You will also need to include values of t^2 in your table.
- 2 Plot a graph of s (y -axis) against t^2 (x -axis).

Analysing your data

- 1 Calculate the gradient of the line of best fit on your graph.
- 2 Use your gradient to calculate the acceleration of the object, in m s^{-2} , as it rolls down the slope.

Evaluation

- 1 Estimate the actual uncertainty in your measurements of s and t and explain how you reached your estimates.
- 2 Suggest, with a reason, which measurement is the largest source of error.
- 3 List any limitations or problems with the method chosen.
- 4 Suggest ways in which the accuracy of the measurements taken could be improved.

Acceleration down a Slope

Teaching Notes

Link to theory

3(g) *solve problems using equations which represent uniformly accelerated motion in a straight line, including motion of bodies falling in a uniform gravitational field without air resistance.*

Key learning objectives

- To highlight the effect that reaction time can have on the results of any human-timed experiment.
- To provide an opportunity for graphical analysis of data including the use of a gradient to analyse the motion.
- To develop the analysis and calculation of errors in experimental work.

Notes

The measurement of the actual length of the slope is likely to be to ± 0.5 mm although it is very hard to accurately note when the object has actually travelled that exact distance. The time measurement could be to about ± 0.2 s, the relatively large uncertainty being due both to the reaction time and to the difficulty in knowing exactly when the ball passes the mark on the slope.

It can be stressed that repeating readings and using a graph to calculate the acceleration will give a more accurate answer. In order to highlight some of these issues, you may wish to present the lesson in the following order.

- Roll the object down the slope.
- Ask students how they could measure the acceleration.
- Work towards the formula $a = 2s/t^2$
- Measure the values of s and t once and calculate a value for a .
- Raise the issue of errors and try and identify ways to gain the best possible value of a .

Before students carry out the graphical analysis in this activity it is important to stress why they are plotting s against t^2 and what information can be gained from the graph. Relating a particular equation to that of a straight line and identifying what variables need to be plotted and what the value the gradient has is a very important skill.

Expected results

Although there will be a fair degree of error in the results, when students plot their graphs they should be able to gain a reasonably straight line. Smaller values of s will give smaller values of t and hence the errors here will be greater. This can be raised in discussions with the students about the work.

Possible extension work

You may wish to precede or follow this experiment with a measurement of the students' reaction times in order to have an actual figure that can be used in the error calculations. Care needs to be taken when doing this as the time it takes for someone to react can change depending upon whether they are expecting an event, such as a ball rolling down a slope nearing a finishing point, or not.

Students could be encouraged to repeat the experiment changing the angle θ between the slope and the horizontal and to investigate the relationship between a and θ .

The most able students could be asked to extrapolate their results to $\theta = 90^\circ$ and to consider why their value for a is substantially different from the acceleration of free fall. Researching the correct explanation will take them well beyond the A level syllabus.

Students could also be asked to investigate whether the object itself had an effect on the value of a by repeating the same experiment for different objects. This could easily be done with different balls (e.g. tennis ball, golf ball, squash ball) or with a solid ball, a hollow ball, a solid cylinder and a tube. Again, to explain the differences will take students well beyond the A level syllabus.

Acceleration down a Slope

Technical Notes

Apparatus requirements

- 1 **Slope.** This can be a long plank of wood at least 1m in length, and preferably longer. It should be stiff enough so that it does not sag in the middle when supported at one end.
- 2 **Lab jack or pile of books** to prop one end of the slope up so that it is inclined.
- 3 **Object to roll down slope.** This may be a mechanics trolley or a smooth ball at least as large as a squash ball. It must roll freely down the slope with little or no resistance. Table tennis balls are not appropriate as they are affected too much by air resistance.
- 4 **Metre rule.**
- 5 **Stopwatch** reading to 0.1 s or better.

Triangle of Forces Board Student Worksheet

In this experiment you will be using a vector triangle to find the weight of an object.

Theory

It is possible to represent and calculate an unknown force using a vector diagram. If a three force system is in equilibrium, then the resultant force is zero and so the force vectors can be represented as a complete triangle. By knowing two of the forces and the angles between them, it is possible to draw a scale diagram and to measure calculate the third force from the diagram.

You will be using this principle to find the weight of various objects in a system in equilibrium.

Making measurements and observations

- 1 Take three equal lengths of thread, each around 0.5 m long. Tie their ends together so that they form a Y shape.
- 2 Tie one of the objects of unknown weight to the end of one thread and tie a small loop in each end of the other two threads.
- 3 Clamp the board in a vertical position. Clamp the two pulleys to the large stiff board, one on each side near to the top. The arrangement should be such that the pulleys are between 0.4 m and 0.7 m apart.
- 4 Attach a clean sheet of white paper to the board behind the pulleys.
- 5 Loop the two threads with loops over the pulleys and add weights to the end until the object in the middle is supported. The two weights and the object of unknown weight must be in equilibrium. You may need to increase or decrease the weights on each side in order to achieve equilibrium. The arrangement is shown in the diagram below.

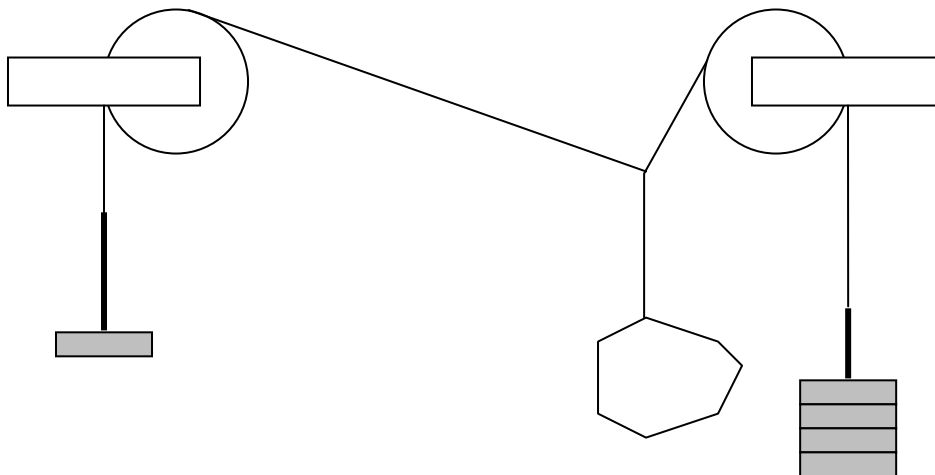

- 6 Record the two weights, making a note of which side of the board they are on.

- 7 Trace the lines of the three threads onto the paper on the board. It is very important that you are able to record the angles between the lines accurately. You may find it easier to put dots on the paper behind the threads and then join them up when the paper is removed.
- 8 Repeat the experiment again for each of the objects of unknown weight.

Recording and presenting your data

- 1 For each object of unknown weight, your results will be the sheet of paper from the forces board.
- 2 From the lines drawn on the piece of paper, measure the angles between the threads.
- 3 Construct a triangle of forces. Begin by drawing the two known forces, starting the second force at the end of the arrow representing the first one. The force arrows must have the correct angle between them. You will need to decide on an appropriate scale to use (e.g. 5 cm = 1 N): the scale you use will depend upon the weights used.
- 4 Connect the point at the start of the first force arrow and the point at the end of the second force arrow with a third arrow. The diagram below shows an example of how the lines on the paper are turned into a force triangle.

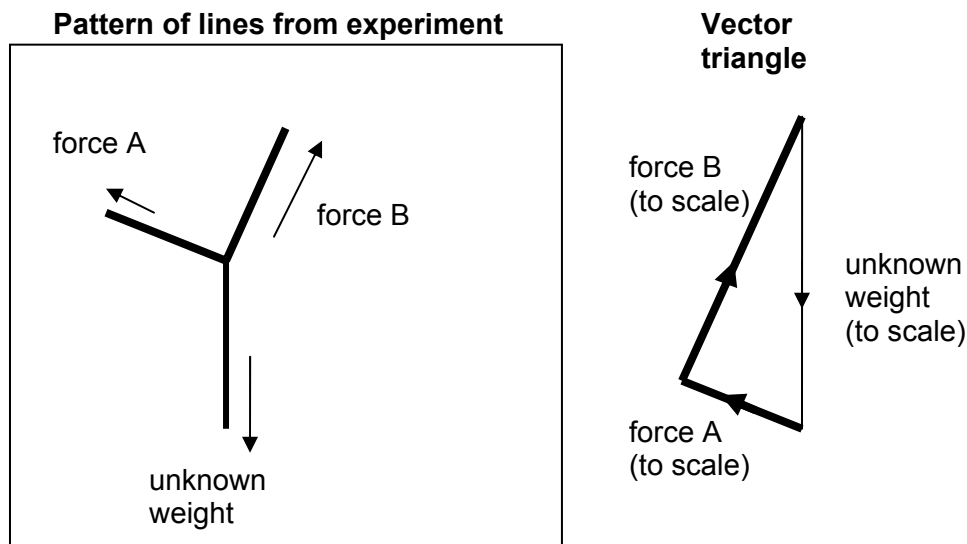

- 5 Repeat 1 – 4 to obtain vector diagrams for each of the objects of unknown weight.

Analysing your data

- 1 Measure the force arrows representing the weight of each the objects of unknown weight.
- 2 Use the scale to calculate each of the unknown weights.

Evaluation

- 1 Ask the teacher for the actual weights of the objects. Write a paragraph comparing your results with the actual weights, commenting on the reasons for the differences.

Triangle of Forces Board

Teaching Notes

Link to theory

5(d) use a vector triangle to represent forces in equilibrium

Key learning objectives

- To visualise what a vector triangle really means.
- To develop students' skills in manipulating apparatus.

Notes

When students draw vector triangles in their work, they sometimes have difficulty in visualising what the diagram really means. This experiment will give them a clear example and will help them to visualise the meaning of vector triangles in other contexts.

As this experiment is a little fiddly, it is a good chance for students to develop their manual dexterity in manipulating apparatus.

Both of the learning objectives should be stressed to the students before they carry out the experiment. They should also be encouraged to take time in order to get good quality results.

At the end of the activity, students will ask for the actual weights of the three unknown objects. These should be given to them on a card.

Expected results

The students will not produce a great deal of written work. Other than a standard account of the experiment, all they will have is the paper from the experiment, the scale drawings of the vector triangles and the comparison between the experimental results and actual weights.

Possible extension work

Students could be asked to suspend two weights each of 5.0 N from the threads that pass over the pulleys. They could investigate the relationship between the angle between these two threads and the weight suspended from the central thread.

Triangle of Forces Board

Technical Notes

Apparatus requirements

- 1 Three different objects of unknown weight.** Many objects will be suitable as long as they have weights between about 0.5 N and 5.0 N and they are easy to tie onto a piece of thread.
- 2 Two 1.0 N weight hangers and six 1.0 N slotted weights.**
- 3 Three A4 sized sheets of white paper.**
- 4 Strong wooden board,** about 50 cm × 50 cm.
- 5 Two stands, two bosses and two clamps.** These are to hold the board securely in a vertical position.
- 6 Two pulleys.** These need to be able to be clamped to the top corners of the board.
- 7 Blu-tack** to attach the sheets of paper to the board.
- 8 Three pieces of strong thread,** each about 50 cm long.
- 9 Card showing the weights of the three objects.** This should be retained by the teacher and not given to the students until the end of the experiment.

Finding the Mass of a Metre Rule using the Principle of Moments Student Worksheet

In this experiment you will use the principle of moments, together with the idea of the centre of gravity, to find the mass of a metre rule.

Theory

The centre of gravity of a body is a point through which the weight of the body acts, or appears to act. A metre rule has a uniform shape and a constant density and so the centre of gravity will be a point exactly in the middle of the rule (at the 50 cm mark).

The principle of moments states that an object is in equilibrium if the sum of all anticlockwise moments about the pivot is equal to the sum of all clockwise moments about the same pivot. If a metre rule is balanced horizontally at any point, this means that the clockwise moments and the anticlockwise moments must be equal.

The arrangement for the experiment is shown in the diagram below.

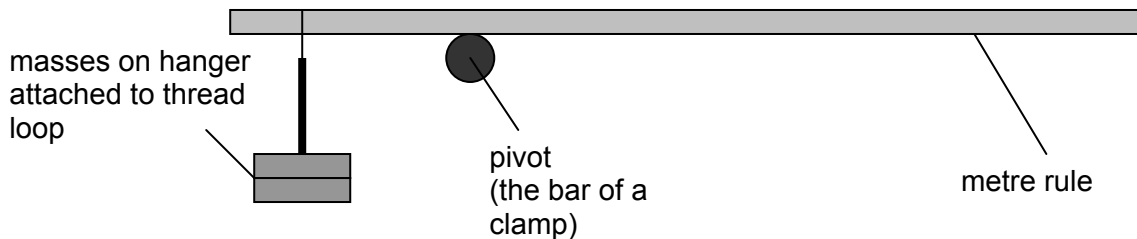

In this situation, the weight F_1 of the masses provides the anticlockwise moment and the weight F_2 of the rule provides the clockwise moment. The weight of the rule acts through the centre of gravity at the middle of the rule. This is shown in the diagram below.

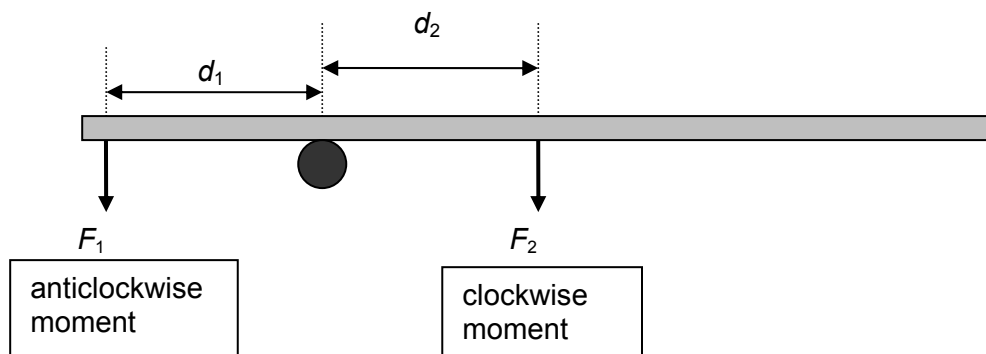

If the rule is balanced, we can apply the principle of moments. This results in the equation

$$F_1 d_1 = F_2 d_2$$

where d_1 is the distance between the hanging mass and the pivot and d_2 is the distance between the pivot and the centre of gravity of the rule. This equation can be rewritten as

$$m_1 g d_1 = m_2 g d_2$$

where m_1 is the mass hanging from the rule, m_2 is the mass of the metre rule and g is the acceleration of free fall.

This can be rearranged to give

$$m_2 = m_1 \times (d_1 / d_2).$$

Making measurements and observations

- 1 Set up the stand, boss and clamp so that the bar of the clamp is horizontal and its height above the bench is a few centimetres more than the length of the mass hanger.
- 2 Hook the thread loop over the zero end of the metre rule.
- 3 Hang the mass hanger from the bottom of the thread loop underneath the metre rule.
- 4 Slide the thread loop so that it is at the 1 cm mark of the metre rule.
- 5 Move the metre rule and the hanging masses so that the metre rule balances horizontally on the bar of the clamp stand. (This may be a bit fiddly, so be patient.)
- 6 When it is balanced, record m_1 , d_1 and d_2 .
- 7 Repeat the experiment for six different values of m_1 .

Recording and presenting your data

- 1 All your measurements should be recorded in a table of results. Your table of results should include a column for m_2 .
- 2 The values in the column for m_2 should be calculated using the equation

$$m_2 = m_1 \times (d_1 / d_2).$$

Analysing your data

- 1 Calculate the average of your values for the mass m_2 of the metre rule.

Evaluation

- 1 Estimate as to the actual uncertainty in each measurement you have taken.
- 2 Describe any steps you took to reduce experimental errors.
- 3 Describe any limitations or problems with the method used to find m_2 in this experiment.
- 4 Suggest ways in which the accuracy of the measurements taken could be improved.

Finding the Mass of a Metre Rule using the Principle of Moments

Teaching Notes

Link to theory

5(i) *apply the principle of moments*

5(e) *show an understanding that the weight of a body may be taken as acting at a single point known as its centre of gravity*

Key learning objectives

- To show an application of the law of moments.
- To use the idea of centre of gravity in a practical context.
- To develop confidence in experiments that require delicate manipulative skills.

Notes

This practical activity does not require the use of a graph and can be used early in the course, before graphical skills have been taught and while students are gaining confidence in the manipulative skills.

The purpose of this activity is to combine the idea of a centre of mass together with the principle of moments and to experimentally find the mass of a metre rule.

Some students may not find it easy to balance the metre rule and will need encouragement. Balancing the rule is easier if the masses are only about 1 cm clear of the bench when the rule is horizontal. The activity is intended to be a confidence building exercise in manipulating equipment.

Expected results

The mass of a metre rule will vary considerably depending upon the material of manufacture. Commonly they tend to have a mass of around 100 g, but given the variation it is a good idea to know the mass before the students carry out the activity.

Possible extension work

More able candidates can be shown a diagram of the arrangement, without being given the student worksheet, and can be asked to find the mass of the metre rule without further instructions. This will begin to develop their planning skills.

Finding the Mass of a Metre Rule using the Principle of Moments

Technical Notes

Apparatus requirements

- 1 Stand, boss and clamp.** The bar of the clamp needs to be long enough to balance a metre ruler on.
- 2 Meter rule.** This should be quite stiff. Wooden metre rules are preferable as plastic ones can bend.
- 3 Loop of thread** long enough to fit loosely around the metre rule.
- 4 10 g mass hanger and nine 10 g slotted masses.**

Finding the Densities of Different Materials

Student Worksheet

In this experiment you will find the densities of several materials, using the principle of moments in your measurements of mass.

Theory

The density ρ of a material is usually measured in kg m^{-3} and is related to the mass m and volume V of an object made from the material by the equation

$$\rho = m / V.$$

In this experiment you will determine the densities of five materials from measurements of six objects, as shown in the table.

material	object
glass	microscope slide
glass	marble
aluminium	sheet of foil
paper	sheet of paper
steel	ball bearing
wood	block of wood

Because you will be making different measurements on six different objects, you will need to think about how to lay out your work so that it is easy to follow. You will need to do this thinking **before** you start to make measurements.

The masses of the objects will be determined using a simple balance and the principle of moments. The balance is constructed from a metre rule, a knife edge and a 50 g mass. These are arranged as shown in the diagram.

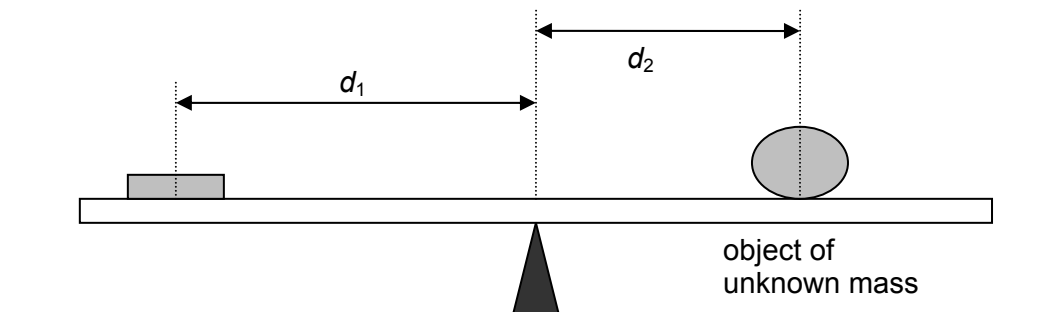

Without the 50 g mass or the object of unknown mass, the metre rule is balanced on the knife edge. Without changing the position of the knife edge under the rule, the 50 g mass and the objects are placed on the rule and their positions are adjusted until the rule balances.

From the principle of moments, it can be shown that

$$m_1d_1 = m_2d_2$$

where $m_1 = 50$ g, m_2 is the unknown mass, d_1 is the distance from the pivot to the centre of the 50 g mass and d_2 is the distance from the pivot to the centre of the unknown mass.

Making measurements and observations

- 1 Use the 30 cm rule to measure the length and width of the sheet of paper. You should repeat your readings at different points and average the results.
- 2 Fold the sheet of paper in half several times. Make a note of how many layers are in the folded sheet.
- 3 Use the micrometer screw gauge to measure the thickness of the folded sheet. Repeat your readings at different points and average the results.
- 4 Use your answers in 2 and 3 to calculate the thickness of a single sheet of paper.
- 5 Repeat 1 – 4 to find the dimensions of the sheet of aluminium foil.
- 6 Use the 30 cm rule and the micrometer screw gauge as appropriate to measure the dimensions of the microscope slide and the block of wood.
- 7 Arrange the glass marbles in a straight line and touching each other, as shown in the diagram.

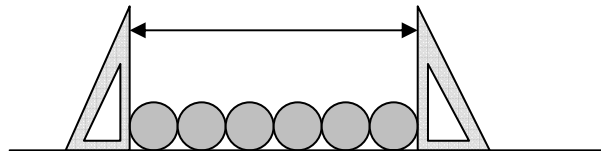

- 8 Use the two set squares and the 30 cm rule to measure the length of the row of marbles.
- 9 Divide your answer to 8 by the number of marbles to obtain the average diameter.
- 10 Divide this figure by two to obtain the average radius r of the marbles.
- 11 Repeat 7 – 9 for the steel ball bearings.
- 12 Balance the metre rule on top of the knife edge. Make a note of the position of the knife edge on the scale of the metre rule.
- 13 Place the 50 g mass and the microscope slide onto the metre rule, as shown in the diagram in the theory section. You may need to use a small piece of Blu-tack to prevent the microscope slide from falling off the metre rule and breaking. The position of the knife edge under the metre rule should not change and the positions of the 50 g mass and the microscope slide should be adjusted so that the metre rule balances on the knife edge.
- 14 Measure and record the distances d_1 and d_2 .
- 15 Repeat 13 and 14 for each object. You may need to use a smaller mass for some of the objects.

Recording and presenting your data

- 1 For each object, record **all** the measurements you have made in a clear way, including the calculation of density. You will need to think about how you lay your work out before you start taking measurements. Remember to leave space for the analysis of your data.

Analysing your data

- 1 Calculate the mass m_2 of each object using the equation

$$m_1 d_1 = m_2 d_2.$$

- 2 Calculate the volume V of each object. For the glass marble and the steel ball bearing, use the equation

$$V = \frac{4}{3} \pi r^3$$

where r is the radius of the sphere.

- 3 Calculate the density ρ of the material from which each object is made, using the equation

$$\rho = \frac{m}{V}.$$

Evaluation

- 1 Suggest, with a reason, the measurement that was the largest source of error in the calculation of the density for each object.
- 2 Suggest ways in which the accuracy of the experiment could be improved.

Finding the Densities of Different Materials

Teaching Notes

Link to theory

9(a) define the term density

Key learning objectives

- To gain familiarity with applying the principle of moments.
- To familiarise students with density values for common materials.
- To gain confidence in using micrometers.

Notes

In many cases the measurements that the students will take for the volume of the object may seem straightforward and may well be something that they have done before. It is important to stress that the degree of accuracy in their measurement needs to be very high and the steps that they need to take in order to get accurate measurements.

Some students may not find it easy to balance the meter rule and may need encouragement and support. One objective of this experiment is to develop their manual dexterity in situations like this. It is worth encouraging them to spend some time getting used to the apparatus before attempting to make accurate measurements.

Expected results

material	approximate density / kg m ⁻³
glass	2000 - 4000
aluminium	2700
steel	7800
paper	600 - 1200
wood	150 - 1200

Possible extension work

Students could be asked to look at the density values for the glass marble and glass microscope slide and to try and comment as to whether they are (or could be) made from the same material.

They could be asked to complete the same experiment for irregular objects that still require precision measurement, e.g. a rubber hose such as one used to connect a Bunsen. This will require students to measure an internal and external diameter in order to calculate the volume of the tube. Blocks that are used to find the specific heat capacity of materials can be used as they require students to measure internal diameters and depths in order to calculate the volume of the block.

Finding the Densities of Different Materials

Technical Notes

Apparatus requirements

- 1 **Sheet of aluminium foil.** This should be neatly cut into a rectangle. The size should be greater than 10cm x 15cm in order to allow it to be folded over several times. It is important to get the edges as straight as possible.
- 2 **Sheet of paper.** Normal A4 writing paper will be fine although any rectangular size with straight edges will be fine.
- 3 **Glass microscope slide.**
- 4 **Six identical steel ball bearings.**
- 5 **Six identical glass marbles.**
- 6 **Rectangular block of wood,** with a mass of less than 200 g.
- 7 **Blu-tack.**
- 8 **Two set squares.**
- 9 **Metre rule.**
- 10 **30cm rule.**
- 11 **Knife edge.** This can be a glass prism or any other edge that can be placed on a table and have a metre rule balanced on it.
- 12 **50 g mass.**
- 13 **10 g mass.**
- 14 **Micrometer screw gauge.**

Notes

Students need to be warned about the dangers of over-tightening the micrometer screw gauge on the microscope slide.

Elasticity and Springs

Student Worksheet

In this experiment you will be testing the behaviour of a spring to see whether it behaves according to Hooke's law and, if so, to find the spring constant.

Theory

Hooke's law states that the extension x of an object is directly proportional to the force F applied. This may be written as

$$F = kx$$

where k is a constant known as the spring constant.

This behaviour only holds true for certain objects under certain loads. Once the load exceeds a limit, known as the limit of proportionality, the behaviour is no longer linear. This is shown in the force-extension graph below.

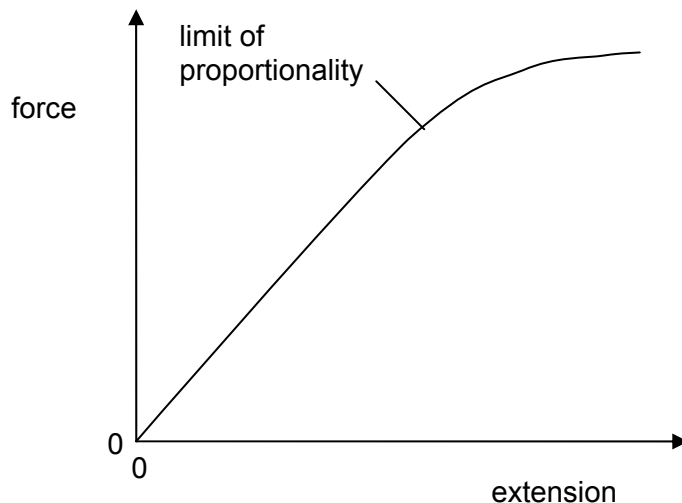

The work that must be done to extend a spring is equal to the area under the force-extension graph.

In this experiment you will:

- find the spring constant for a spring that you have been given;
- find the energy stored in that spring for a certain force by calculating the area under the force-extension graph;
- investigate the same behaviour for different arrangements of springs in series and parallel.

Making measurements and observations

Safety Notice During this experiment springs will be extended under various loads. There is a chance that a spring will come loose and fly off. You must wear safety glasses at all times during this experiment.

- 1 Take a single spring and loop it over the bar of a clamp attached to a stand.
- 2 Attach a second clamp to the stand and use this to hold a half-metre rule. Arrange the rule close to the spring and in a position where it is easy to take a reading of the length of the spring. The arrangement is shown in the diagram.

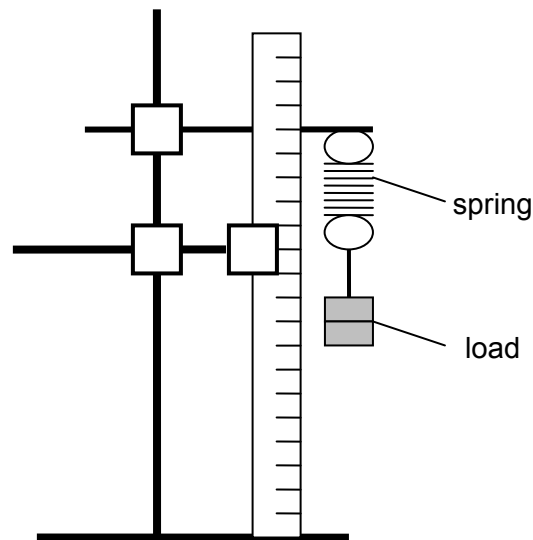

- 3 Measure the total length of the unloaded spring. You may wish to use a pair of set squares to help get accurate readings.
- 4 Add a mass m to the spring.
- 5 Calculate the load F on the spring using

$$F = mg$$

where $g = 9.8 \text{ m s}^{-2}$.

- 6 Record the load and the new length of the spring.
- 7 Repeat 4 – 6 for values of m in the range $0 \leq m \leq 0.40 \text{ kg}$.
- 8 Continue adding greater loads until the spring fails. This will often happen because the loop at the end unwinds. If you need to, you should ask your teacher for extra masses.
- 7 Repeat 3 - 7 for different arrangements of springs in series and parallel such as those shown below. Do **not** test these springs to failure. In each case, the total mass should **not** go above 0.40 kg.
When connecting the springs in parallel, you will need to use a small piece of wooden dowel through the bottom loops of the spring. You should hang the loads from the piece of dowel so that the load is distributed between the springs. You may need to use small pieces of Blu-tack to stop the dowel from slipping.

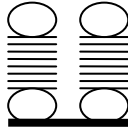
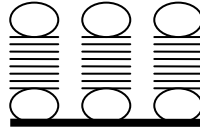
single
springtwo springs
in parallelthree springs
in paralleltwo springs
in seriesthree springs
in series

Recording and presenting your data

- 1 For each combination of springs (including the single spring), draw up a table of results showing **all** the measurements you have taken. Each table of results should include a column for the extension of the springs.
- 2 For each combination of springs (including the single spring), plot a graph of force F (y -axis) against extension x (x -axis).

Analysing your data

- 1 Use the force-extension graph for the single spring to calculate the energy required to extend the spring to the limit of proportionality.
- 2 Calculate the gradient of the linear section of each of your force-extension graphs.
- 3 Use your answers to **2** to determine the spring constant k for each combination of springs (including the single spring).
- 4 For each combination of springs (including the single spring), calculate the value of k / K where K is the spring constant of the single spring.
- 5 Comment on your answers to **4**, drawing parallels to the resistances of combinations of electrical resistors.

Evaluation

- 1 Describe any steps that you took to reduce errors.
- 2 Any limitations or problems with the method chosen.
- 3 Suggest one way in which the accuracy of the measurements could be improved.

Elasticity and Springs

Teaching Notes

Link to theory

- 10(b) describe the behaviour of springs in terms of load, extension, elastic limit, Hooke's law and the spring constant (i.e. force per unit extension)
- 10(f) deduce the strain energy in a deformed material from the area under a force extension graph

Key learning objectives

- To demonstrate the behaviour of materials that obey Hooke's law.
- To show what happens to a spring that is loaded beyond its elastic limit.

Notes

This experiment should be done before the Young modulus experiment as many of the foundation ideas of that practical are found in this one. They follow one into the other.

The students work will include calculations and a number of graphs. The key points to look for in their work are

- the correct identification of the limit or proportionality on the graph for a single spring;
- the correct area under the graph calculated (the most common mistake is to use g and cm instead of N and m , giving power of 10 errors);
- a correct value of the spring constant for the single spring.

Expected results

arrangement	value of k / K
single spring	1
two springs in series	$\frac{1}{2}$
three springs in series	$\frac{1}{3}$
two springs in parallel	2
three springs in parallel	3

Possible extension work

Students can use their force-extension graph for a single spring as a calibration graph. They can suspend some objects from the spring and, by measuring the extension, determine the weight.

Elasticity and Springs

Technical Notes

Apparatus requirements

- 1 **Stand, two bosses and two clamps.**
- 2 **Two set squares.**
- 3 **Blu-tack.**
- 4 **Half-metre rule.**
- 5 **100 g mass hanger and nine 100 g slotted masses.**
- 6 **Small piece of dowel**, about 10 cm in length, which can fit through the loops at the ends of the springs.
- 7 **Four springs**, identical, with loops at both ends. The spring constant should be approximately 25 N m^{-1} and the springs should fail with loads of more than 400 g but less than 1.0 kg. Expendable steel springs are suitable.
- 8 **Safety glasses or goggles.**

Notes

Even though the loads are relatively low, eye protection needs to be worn because, when the spring fails, it may fly off in an unpredictable direction.

Finding the Young Modulus of a Wire

Student Worksheet

In this experiment you will take measurements to determine the Young modulus of a wire.

Theory

The Young modulus E of a wire is a measure of the stiffness of a material. It is a very important property of materials in engineering design. It is defined by the equation

$$E = \text{stress} / \text{strain}$$

where

$$\text{stress} = \text{applied force} / \text{cross-sectional area}$$

$$\text{strain} = \text{extension} / \text{original length.}$$

So the equation for the Young modulus may be written

$$E = Fl / Ax$$

where F is the applied force, x is the extension, A is the cross-sectional area and l is the original length.

In the experiment you will measure the dimensions of a wire. You will then apply a force to the wire and measure how much it extends. The arrangement for carrying out the experiment is shown in the diagram below.

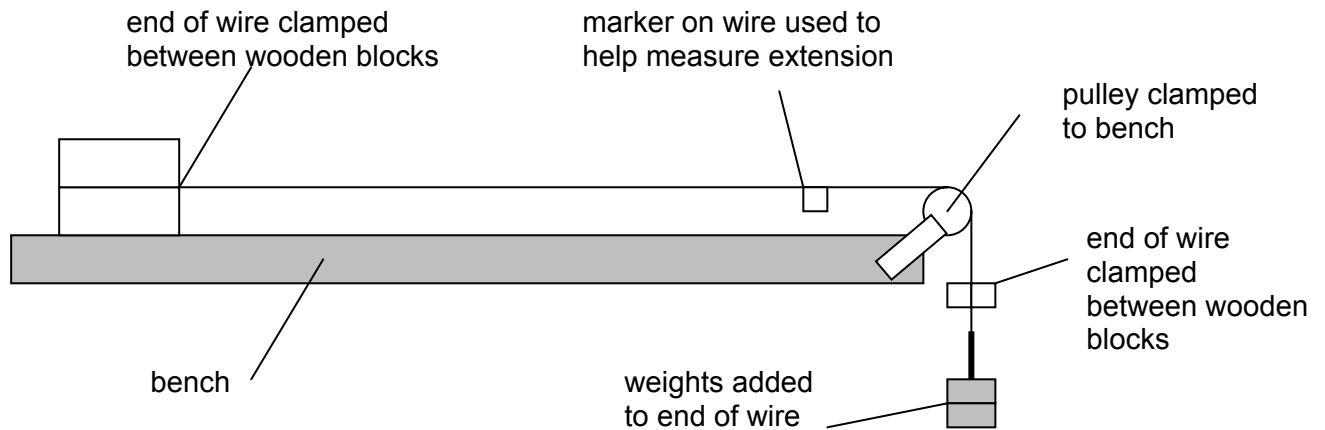

Making measurements and observations

Safety notice: During this experiment there will be large forces involved and a wire under tension that may snap. If it snaps, the wire may whip back and strike you. You must wear safety glasses at all times during this experiment.

- 1 Measure the diameter d of the piece of wire with a micrometer screw gauge. Repeat this several times along the length of the wire, rotating the wire each time.
- 2 Clamp one end of the wire between two wooden blocks and to the bench with a G clamp. It is important that this is clamped tightly and will not slip.

- 3 To the other end of the wire clamp two smaller blocks, again very tightly. Around these blocks tie a loop of string. This loop needs to be strongly tied so that it is able to support a number of kilograms without slipping or breaking. The load will be hung from this loop.
- 4 Attach the pulley to the end of the bench or table and hang the end of the wire over it so that it hangs just below the pulley.
- 5 Place a small piece of tape on the wire around 25 cm from the pulley. This will act as the marker for the end of the section of wire that you are considering.
- 6 Make sure that the wire is taut and free from kinks. The wooden blocks clamped to the end should do this but if not then add a small weight to the end in order for the wire to just straighten out. Do **not** include this weight in your calculations.
- 7 Measure the unstretched length l of the section of wire from the end of the wire clamped to the bench to the tape marker from 4.

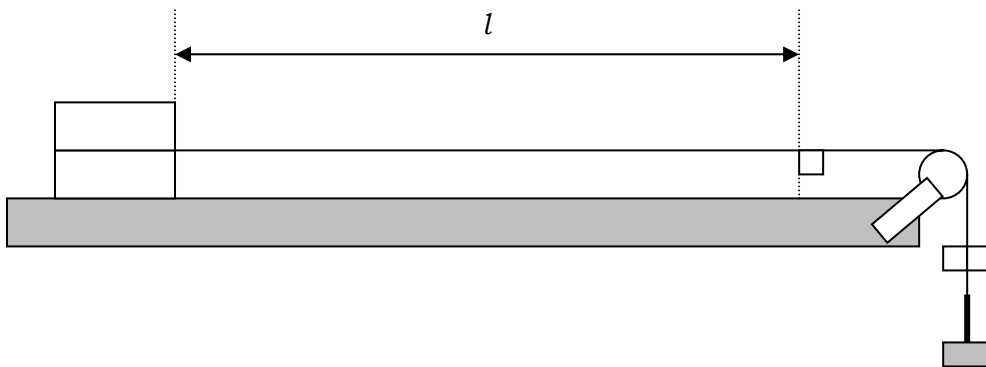

- 8 Fix a metre rule to the table directly below the wire so that you can measure its extension as loads are added.
- 9 Add a mass $m = 0.50$ kg to the end of the wire. After a brief while, measure the extension x of the section of wire as shown in the diagram.

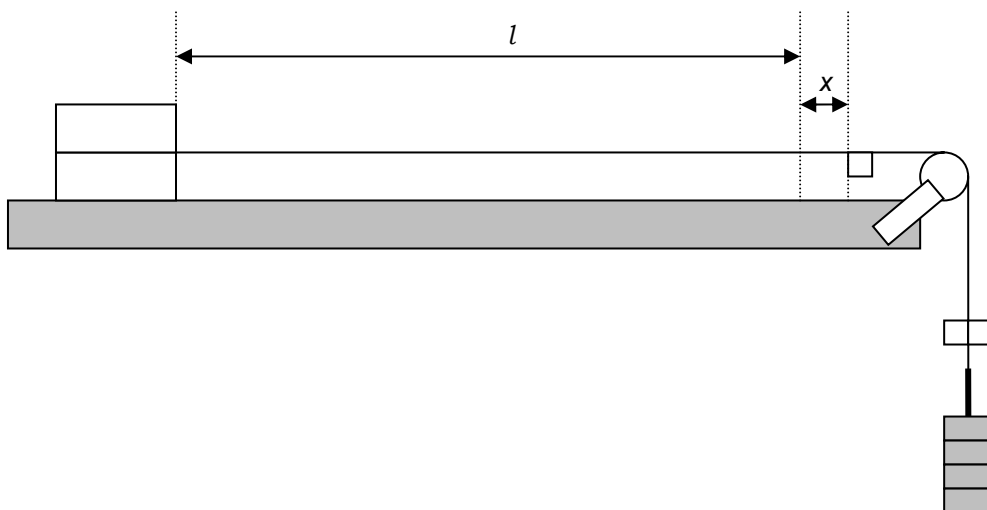

- 10** Continue to increase the load on the wire by increasing the mass m in 0.50 kg steps. For each load, let the wire settle and then record the extension x . Continue until you have six sets of readings for m and x . Take care when adding the loads in case the wire snaps.

Recording and presenting your data

- 1** Calculate the cross-sectional area A of the wire using the equation

$$A = \frac{1}{4}\pi d^2.$$

- 2** Record your values for m and x in a table of results. Include columns for F and for the stress and the strain, where

$$F = mg$$

$$\text{stress} = F / A$$

$$\text{strain} = x / l$$

and where $g = 9.81 \text{ m s}^{-2}$.

- 3** Plot a graph of stress (y -axis) against strain (x -axis).

Analysing your data

- 1** Calculate the gradient of your graph.
2 The Young modulus E of the material of the wire is given by the equation

$$E = \text{stress} / \text{strain}.$$

Use your answer to **1** to determine the Young modulus of the material of the wire.

Evaluation

The procedure you carried out including what steps were taken to reduce error.

- 1** Estimate the actual error in each measurement taken.
- 2** Describe any limitations or problems with the method used to determine the Young modulus.
- 3** Suggest why a large value of l was used in this experiment.
- 4** Suggest two ways in which the accuracy of the measurements taken could be improved.
- 5** Look up the 'true' value for the Young modulus of the material of your wire. Comment on the difference between this 'true' value and the value you obtained from your experiment.

Finding the Young Modulus of a Wire

Teaching Notes

Link to theory

10(c) *define and use the terms stress, strain and the Young modulus*

10(d) *describe an experiment to determine the Young modulus of a metal in the form of a wire.*

Key learning objectives

- To experimentally determine a value of the Young modulus of a material.
- To illustrate the importance of making some variables large in order to reduce errors in small readings.

Notes

This experiment should be carried out with a wire several metres long, and therefore requires a significant amount of bench space. Care must be taken to ensure that students wear safety glasses or goggles throughout this experiment.

Expected results

material of wire	Young modulus / N m^{-2}
copper	1.3×10^{11}
constantan	1.6×10^{11}
aluminium	7.1×10^{10}

Possible extension work

Students may wish to investigate the Young's modulus of two wires made of the same material but different thicknesses. Theory suggests that the value should be the same regardless of thickness and students can be asked to check that this is the case.

There is also scope for investigating the behaviour under load of other materials; such as fishing line, elastic bands, or strips of thin plastic sheeting (such as that used in the manufacture of carrier bags). If the increment of loads is well chosen it should be possible to see the plastic deformation happening as the plastic appears to 'flow'.

As with the main experiment, eye protection needs to be worn.

Finding the Young Modulus of a Wire

Technical Notes

Apparatus requirements

- 1 **Piece of copper wire**, between 2m and 3m in length. If copper is not available then other metals can be used. When prepared the wire must be undamaged and without kinks or bends. The suitable length of wire will depend a great deal upon the length of benching available where the experiment is done.
- 2 **Four blocks of wood**. Two large blocks are needed to clamp the wire to one end of the bench. Two smaller blocks are needed to clamp to the wire at the other end where it is loaded.
- 3 **Two G clamps**. A large one is required to clamp the wire to the bench and a smaller one to clamp to the end of the wire from which the masses are to be hung.
- 4 **Piece of strong string**. This is used to wrap around the blocks clamped to the end of the wire from which the masses are to be hung. It needs to be able to take a large force without breaking so it is suggested that it is wrapped round several times to prevent accidental breaking.
- 5 **Metre rule**.
- 6 **Adhesive tape**.
- 7 **Scissors**.
- 8 **Mass hanger and masses**. This experiment uses large masses, and in the end it is quite possible that several kilograms will be loaded on the wire, depending on the thickness of wire used. It is possible to make the hook for the masses such that it can take several fully loaded (1kg) mass hangers. Students must be able to vary the mass in steps of 500 g.
- 9 **Safety glasses or goggles**. These need to be worn at all times during this experiment. One pair per student.

Measuring the Resistivity of a Wire

Student Worksheet

In this experiment you will be making measurements of voltage and current for a piece of metal wire, together with the physical dimensions of the wire, from which you will calculate the resistivity of the metal.

Theory

The resistance R of a component in a circuit is given by the equation

$$V = IR$$

where V is the potential difference across the component and I is the current in the component.

The resistance of a wire is given by the equation

$$R = \rho l / A$$

where ρ is the resistivity of the metal from which the wire is made, l is the length of the wire and A is its cross-sectional area.

Using the circuit below, you will make measurements of current and voltage for different lengths of wire. You will plot a graph of resistance against length and from this you will calculate the resistivity.

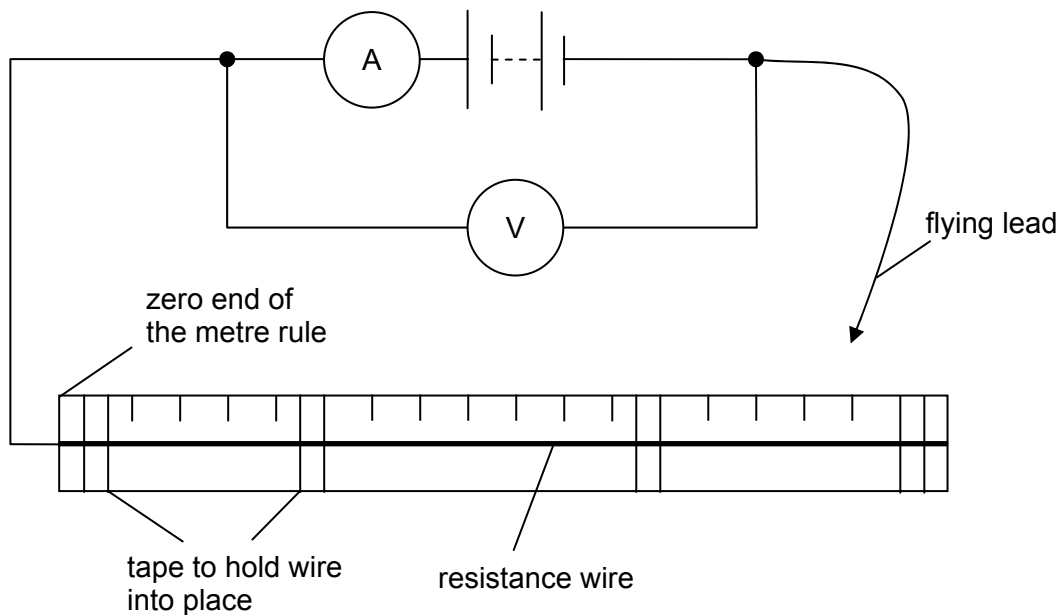

Making measurements and observations

- 1 Use the micrometer screw gauge to measure the diameter d of the resistance wire in several places along the length. Each time you take a measurement at a new place, rotate the wire slightly.
- 2 Tape the wire to the metre rule so it cannot slip and the markings of the rule are visible.
- 3 Connect the circuit shown in the diagram above. The flying lead should have a bare conducting end and should be long enough to touch any part of the resistance wire.
- 4 Using the flying lead, make a contact with the resistance wire so that a length $l = 1.00$ m of resistance wire is in the circuit. Record the readings from the ammeter and the voltmeter. Disconnect the flying lead.
- 5 Repeat 4 until you have nine sets of readings where $0.10 \text{ m} \leq l \leq 1.00 \text{ m}$.

Recording and presenting your data

- 1 Your readings should be recorded in a table of results with columns for length l , potential difference V , current I and resistance R . Record the lengths in metres and the current in amperes.
- 2 Plot a graph of R (y -axis) against l (x -axis). Draw a line of best fit.

Analysing your data

- 1 Calculate an average value for the diameter d of the wire.
- 2 Calculate the cross-sectional area A of the wire using the equation

$$A = \frac{1}{4}\pi d^2.$$

- 3 Determine the gradient of your graph.
- 4 Use the equation

$$R = \rho l / A$$

and your answers to 2 and 3 to calculate a value for the resistivity ρ of the metal of the wire. Show your working.

Evaluation

- 1 Describe any limitations or problems that you encountered with the method used.
- 2 Suggest ways in which the accuracy of the measurements could be improved.
- 3 Look up the actual value for the resistivity of the metal of your wire. Compare your experimental value to the actual value and comment upon the accuracy of your experiment.

Measuring the Resistivity of a Wire

Teaching Notes

Link to theory

19(h) recall and solve problems using $V = IR$

19(l) recall and solve problems using $R = \rho l/A$

Key learning objectives

- To gain experience in setting up electrical circuits from instructions and a circuit diagram.
- To gain experience in selecting the correct range on a digital multimeter.
- To gain experience in relating a formula to a graph in order to calculate the value of a constant.
- To reinforce learning about resistance and resistivity.

Notes

If students have not previously used digital multimeters, then it is worth spending some time discussing how to select the correct range. This is important as some multimeters have small internal fuses that are easily blown.

Some students may have difficulty relating the gradient of the graph to the equation and may need help and support with the analysis.

Students will be asked to look up the resistivity of the metal of their wire. It is useful to have a data book or internet access available (and to know the metal being used).

Expected results

material	resistivity / $\Omega \text{ m}$
constantan	4.7×10^{-7}
nichrome	1.5×10^{-6}
copper	1.7×10^{-8}
stainless steel	9.6×10^{-7}

Possible extension work

Different thickness of wire of the same material can be investigated to see if the resistivity is the same.

Students could also be asked to make resistors of a fixed value (e.g. 10Ω) from a piece of wire wrapped round a wooden dowel or pencil. They would need to calculate the length of wire needed and to check their results with an ammeter and a voltmeter.

Measuring the Resistivity of a Wire

Technical Notes

Apparatus requirements

- 1 Piece of resistance wire**, 110 cm long. This can be constantan wire (sometimes known as eureka wire) or nichrome wire, usually 28-32 swg. Other diameters and metals can be used as long as it is checked that a good set of results can be obtained beforehand.
- 2 Two digital multimeters.**
- 3 Low voltage power supply.** This can be a number of cells connected together in series if needed. A p.d. of about 3 V will suffice.
- 4 Five connecting leads.** One of these should be at least 70 cm long.
- 5 Crocodile clip.**
- 6 Metre rule.**
- 7 Tape** to fix the wire to the metre rule.
- 8 Micrometer screw gauge.**

Notes

The resistance wire must be checked to ensure that it does not become too hot when 10 cm is connected across the terminals of the power supply. If it does become hot, the students should be warned at the start of the experiment. Depending on the resistance wire used, it may be necessary to instruct the students not to use small lengths of resistance wire in their circuit.

Potential Divider Student Worksheet

In this experiment you will use a rheostat as a potential divider and will investigate the properties of the potential divider.

Theory

The circuit diagram below shows a potential divider circuit.

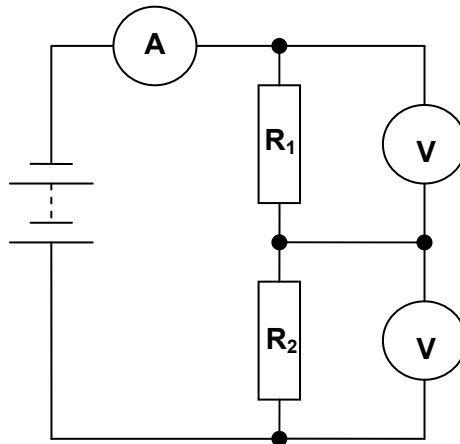

The potential difference V_1 across resistor R_1 , the potential difference V_2 across resistor R_2 , and the potential difference V_t across the power supply are related by the equations

$$V_t = V_1 + V_2$$

$$V_1 = V_t \times R_1 / (R_1 + R_2)$$

$$V_2 = V_t \times R_2 / (R_1 + R_2)$$

where R_1 is the resistance of resistor R_1 and R_2 is the resistance of resistor R_2 .

When using a rheostat, the physical arrangement is slightly different but the principle is exactly the same. It can be useful to imagine that the slider splits the rheostat into two separate resistors in series, whose total resistance is the same as the sum of the two imaginary ones. The circuit diagram for the experiment is shown on the next page.

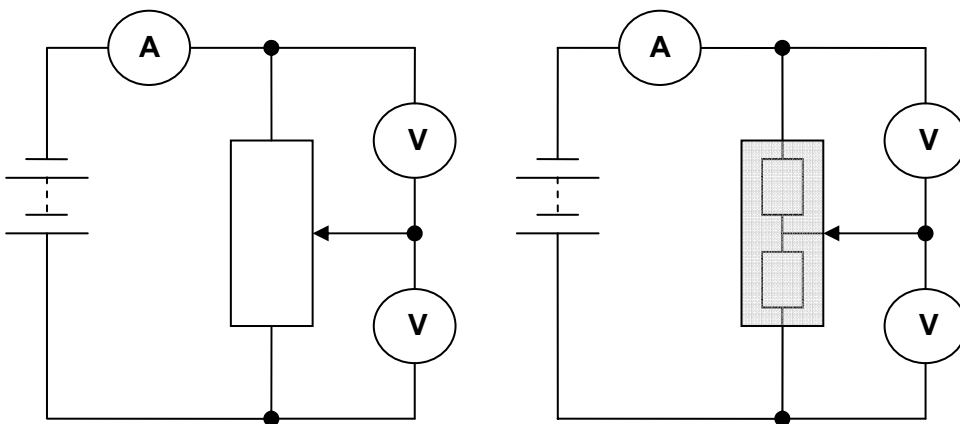

Making measurements and observations

- 1 Connect the circuit up as shown in the diagram. You may find it difficult to relate the circuit diagram to the rheostat, so make sure you are confident that you have set the experiment up correctly before you begin.
- 2 Move the slider on the rheostat close to (but not at) one of the ends.
- 3 Switch the power supply on. Record the readings V_1 and V_2 from the two voltmeters the reading I from the ammeter. Switch the power supply off.
- 4 Move the slider on the rheostat along to a new position.
- 5 Repeat 3 and 4 so until you have 8 sets of readings.

Recording and presenting your data

- 1 Record all your sets of results for V_1 , V_2 and I in a table of results. Include in your table of results columns for R_1 , R_2 , $(R_1 + R_2)$ and $(V_1 + V_2)$.
- 2 Calculate the values for R_1 and R_2 using the equation

$$V = IR.$$

Analysing your data

- 1 Comment on the values you have obtained for I , $(R_1 + R_2)$ and $(V_1 + V_2)$. You should include an explanation for any patterns you observe.

Evaluation

- 1 Estimate the percentage uncertainty in your measurements of each quantity.

Potential Divider

Teaching Notes

Link to theory

20(j) *show an understanding of the use of a potential divider circuit as a source of variable p.d.*

Key learning objectives

- To give candidates experience in setting up a simple electrical circuit from instructions and a circuit diagram.
- To reinforce learning about potential divider circuits.

Notes

The reason for using a rheostat in this practical is to show that, although the voltage across each resistor may change, the total voltage stays the same (as does the current). As they move the slider the voltmeter readings will change but the total of the two should remain constant at the p.d. across the power supply. The current should also remain constant. Seeing this happen is an important part of understanding what the potential divider is doing.

Expected results

I , $(R_1 + R_2)$ and $(V_1 + V_2)$ all remain constant.

Possible extension work

After the students have carried out their experiment the circuit can then be adapted so that a lamp is connected across one half of the potential divider circuit. You will need to choose a suitably rated lamp and an appropriate voltage for the supply. This can be described to the students as the principle of a light dimmer switch, the volume control on a stereo and many other variable power controls.

Alternatively, students could be given a power supply, a voltmeter, one resistor of known resistance and a selection of resistors of unknown resistance. They could be asked to use a potential divider circuit to discover the resistances of the unknown resistors.

You may wish to allow students to set up and investigate potential dividers containing one fixed resistor and an LDR or thermistor, varying the temperature/light intensity and measuring the corresponding voltage values.

Potential Divider

Technical Notes

Apparatus requirements

- 1 **Rheostat**, approximately 2A, 6 Ω although a similar one will do.
- 2 **12 V d.c. power supply.**
- 3 **Three digital multimeters.**
- 4 **Seven connecting leads.**

Measuring g using a Pendulum

Student Worksheet

In this experiment you will measure the time it takes a pendulum to oscillate and will use this data to calculate a value for the acceleration due to gravity.

Theory

For small swings, the period of motion of a simple pendulum can be described by the equation

$$T = 2\pi \sqrt{l/g}$$

where T is the time period for one full swing, l is the length of the pendulum and g is the acceleration of free fall.

Making measurements and observations

- 1 Fix a pendulum to a clamp and stand as shown in the diagram.

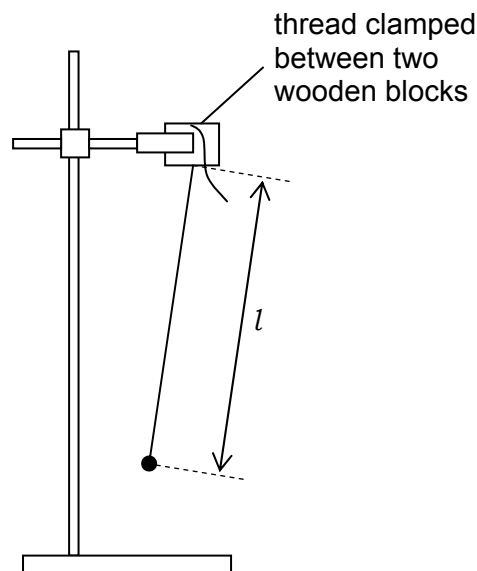

- 2 Practice a few times releasing the pendulum and timing ten complete swings. A complete swing is when the pendulum bob moves:
 - from the central position,
 - out to the left,
 - back through the central position,
 - out to the right,
 - and back to the central position again.
 It is important to try and ensure that the pendulum only moves in one plane and does not 'wobble'.
- 3 Measure and record the length l of the pendulum.
- 4 Measure and record the time period T_{10} taken for ten complete swings of the pendulum.

- 5 Adjust the length l of the pendulum.
- 6 Repeat **3**, **4** and **5** until you have eight sets of readings for l and T_{10} .

Recording and presenting your data

- 1 Your table of results should include columns for l , T_{10} , the period T for one complete swing, and T^2 .
- 2 Plot a graph of T^2 (y -axis) against l (x -axis). Draw a line of best fit.

Analysing your data

- 1 Determine the gradient of your graph.
- 2 Use your answer to **1** and the equation

$$T = 2\pi \sqrt{l/g}$$

to determine a value for the acceleration of free fall g .

Evaluation

- 1 Describe any limitations or problems with the method you used.
- 2 Suggest ways in which the accuracy of the measurements taken could be improved.

Measuring g using a Pendulum

Teaching Notes

Link to theory

This experiment does not link directly to the AS theory. However, it is a useful exercise for the teaching of practical skills.

Key learning objectives

- To provide an experimental method of the determination of g .
- To provide experience of the use of a fiducial marker.
- To give students experience of having to re-arrange a formula and compare it to that of a straight line.
- To give an opportunity to calculate the gradient of a linear graph and identify an unknown variable.

Notes

Whilst the equation for the behaviour of the pendulum does not need to be known for the AS course, this experiment provides an excellent opportunity for developing practical skills in taking readings as well as the subsequent data analysis. The emphasis on the experimental and analytical process, rather than the content, should be stressed to the students. Often students do not measure the correct value of the time, thinking that half one full swing is one full oscillation. This needs to be explained to them before the activity.

The use of a fiducial marker to aid the timing may need to be explained to the students before they carry out the experiment. They may be able to use the line of the clamp stand as a marker if they wish although this is not as precise.

Possible extension work

There are a number of possible developments of this practical although these are best left until the simple harmonic motion section of the A2 course is covered.

Measuring g using a Pendulum

Technical Notes

Apparatus requirements

- 1 **Pendulum bob.**
- 2 **Thread**, 1.20 m long.
- 3 **Clamp stand and boss.**
- 4 **Stopwatch** reading to 0.1s or better.
- 5 **Metre rule.**
- 6 **Cork with pin stuck in it.** For use as a fiducial marker to aid timing.

Appendix 3: Useful resources

The following two books provide support and guidance for teaching practical skills in A level physics as well as containing more suggestions for practical activities, most of which are appropriate for this course.

Advanced Level Practical Work for Physics – Chris Mee and Mike Crundell. (Hodder and Stoughton ISBN 0-340-78248-5).

Advanced Physics Laboratory Book – Peter Warren (John Murray ISBN 0-7195-8054-4).

CIE publishes some books and booklets that also provide support and advice with respect to practical work.

Teaching and Assessing Practical Skills in Science – Dave Hayward (CIE Publications) (aimed at IGCSE and O level rather than A/AS level, but contains some useful advice and information).

Planning for Practical Science in Secondary Schools (CIE publications June 2002)

The CIE website <http://www.cie.org.uk> has many resources that are designed to support teachers. Of particular interest is a practical video that is available on-line through the teacher support site <http://teachers.cie.org.uk>. There are also details about other, more general A level Physics text books in the **Resources** section relating to the 9702 A/AS level Physics course.

The Institute of Physics and Nuffield Curriculum Centre maintain a practical physics website at <http://www.practicalphysics.org>. This website contains over 300 suggestions for demonstrations and practical activities. This resource is free and open to all although you may need to adapt the activities to suit your own needs.

Teaching A2 Physics Practical Skills

Contents

Introduction	1
Why should I read this booklet?	1
How much teaching time should I allocate to practical work?	1
Can I use the practicals in these booklets in a different order?	1
What resources will I need?	2
Is there a limit to the class size?	2
Why should I teach my students practical skills?	3
Points to consider	3
What are the practical skills required by this course?	5
Summary of each of the seven skills	5
A sequence for introducing the skills	7
Ways of doing practical work	9
Keeping records	12
How is a practical activity organised?	13
Teaching A2 skills	15
The feel of practical work in the A2 year	15
Extending AS practical skills for the A2 year	15
Teaching students to plan experiments	16
Teaching students to evaluate conclusions	19
Designing a practical course for the A2 year	23
Planning the course	23
Using past exam papers	24
Planning lessons and teaching the course	24
Planning for a circus	25
Appendix 1: Possible A2 practical activities	26
Appendix 2: Examples of A2 practicals	39
Newton's Law of Cooling	40
Specific Heat Capacity of Oil	44
Specific Latent Heat of Vaporisation of Water	49
Discharge of a Capacitor	54
Investigation with a Hall Probe	58
Force on a Current-Carrying Wire	63
Behaviour of a Light-Dependent Resistor	67
The Temperature Characteristic of a Thermistor	71
The Operational Amplifier as an Inverting Amplifier	76
Cantilever Investigation	81
Appendix 3: Useful resources	86

Introduction

You may have been teaching AS and A level physics for many years or perhaps you are new to the game. Whatever the case may be, you will be keen to ensure that you prepare your students as effectively as possible for their examinations. The use of a well-structured scheme of practical work will certainly help in this ambition. However it can do so much more. Science students who are thoroughly trained and experienced in practical skills will have a 'feel' for the subject and a confidence in their own abilities that is far greater than that of students with a purely theoretical background. It is true that there are branches of physics that might be described as purely theoretical but they are in the minority. Essentially, physics is an experimental subject and we owe it to our students to ensure that those who pursue science further have the necessary basic practical skills to take forward into their future careers. Furthermore, the basic skills of planning, analysis and evaluation will be of great value to those who pursue non-science careers.

Why should I read this booklet?

You may be wondering why you should need a booklet like this. If your practical skills are of a high order and you feel confident teaching these skills to others, you probably don't need it (although you might find some of the exercises described in the appendices useful). However, if you are like the majority of us, a little help and support is likely to be appreciated. This booklet aims to provide at least some of this support.

The booklet is designed for the teacher, not for the student. Its objective is to provide a framework within which teachers can develop their confidence in teaching practical skills. Experience suggests that as this confidence grows, the time that teachers are prepared to spend on teaching practical skills also grows.

How much teaching time should I allocate to practical work?

The syllabus stipulates that at least 20% of teaching time should be allocated to practical work. This is in addition to any time the teacher chooses to use for practical demonstrations to illustrate the theory syllabus.

This emphasis on practical work is not misplaced. If the specific practical papers (papers 3 and 5) are considered in isolation, they represent 23% of the examination. However, practical work is not merely a necessary preparation for the practical papers. Questions in the theory papers may also assume an understanding of experimental data or practical techniques. The theory papers also give a considerable weighting to the skills of handling, applying and evaluating information, and one of the ways in which students acquire these skills is through their course of practical work.

In planning a curriculum, teachers should therefore expect to build in time for developing practical skills. If, for example, the time allowed is 5 hours per week over 35 weeks, then a minimum of 1 hour per week should be built into the plan, so that over the year, a minimum of 35 hours is made available. Bearing in mind the weighting given to assessment objectives that relate to information handling and problem solving, 35 hours should be regarded as an absolute minimum.

Can I use the practicals in these booklets in a different order?

It is assumed in these booklets that for A level candidates, the AS work will be taught in the first year of the course, with the A2 work being covered in the second year. If the linear A Level assessment route is used, care should be taken with regard to the order in which practical exercises are used, as the skills practiced in these booklets are hierarchical in nature, i.e. the basic skills established in the AS booklet are extended and developed in the

A2 booklet. Thus, students will need to have practiced basic skills using AS exercises before using these skills to tackle more demanding A2 exercises.

The exercises in these booklets are given in syllabus order. A teacher may well decide to use a different teaching sequence, but the point made above regarding AS and A2 exercises still applies.

What resources will I need?

For a practical course in A-level physics to be successful, it is not necessary to provide sophisticated equipment. Some of the more advanced practicals in these booklets may require less easily obtainable equipment, but the vast majority can be performed using the basic equipment and materials in the laboratory.

A list of basic resources regularly required for assessment may be found in the syllabus. A more detailed list of apparatus suitable for teaching purposes may be found in the CIE booklet '*Planning For Practical Science in Secondary Schools*'.

Is there a limit to the class size?

There is a limit to the class size that is manageable in a laboratory situation, particularly when students may be moving about. The actual size may be determined by the size of the room, but as a general guide, 15 - 20 students is the maximum that one teacher can reasonably manage, both for safety reasons and so that adequate support can be given to each student. Larger numbers would require input from another person with appropriate qualifications, or alternatively would require the class to be divided into two groups for practical lessons.

Why should I teach my students practical skills?

Although this section is likely to be read once only, it is arguably the most important, for if it convinces some readers that practical work is an essential part of physics and underpins the whole teaching programme, one of the aims of publishing this booklet will have been achieved.

Points to consider

- It's fun! The majority of students thoroughly enjoy practical work. The passion that many scientists have for their subject grew out of their experiences in practical classes. Students who enjoy what they are doing are likely to carry this enthusiasm with them and so be better motivated in all parts of the course.
- Learning is enhanced by participation as students tend to remember activities they have performed more easily, thus benefiting their long-term understanding of the subject. Students who simply memorise and recall facts find it difficult to apply their knowledge to an unfamiliar context. Experiencing and using practical skills helps develop the ability to use information in a variety of ways, thus enabling students to apply their knowledge and understanding more readily.
- The integration of practical work into the teaching programme quite simply brings the theory to life. Teachers often hear comments from students such as "I'm glad we did that practical because I can see what the book means now." and "It's much better doing it than talking about it."
- Physics, in common with other sciences, is by its very nature a practical subject – both historically and in the modern world. The majority of students who enter careers in science need to employ at least basic practical skills at some time in their career.
- A practical course plays a part in developing many cross-curricular skills including literacy, numeracy, ICT and communication skills. It develops the ability to work both in groups and independently with confidence. It enhances critical thinking skills and it requires students to make judgements and decisions based on evidence, some of which may well be incomplete or flawed. It helps to make students more self-reliant and less dependent on information provided by the teacher.
- The skills developed are of continued use in a changing scientific world. While technological advances have changed the nature of many practical procedures, the investigative nature of practical science is unchanged. The processes of observation, hypothesis formation, testing, analysis of results and drawing conclusions will always be the processes of investigative science. The ability to keep an open mind in the interpretation of data and develop an appreciation of scientific integrity is of great value both in science and non-science careers.
- Practical work is not always easy and persistence is required for skills and confidence to grow. Students often relish this challenge and develop a certain pride in a job well done.
- The more experience students have of a variety of practical skills, the better equipped they will be to perform well in the practical exams, both in terms of skills and confidence. Some teachers have argued that the skills required for Paper 3 can be developed simply by practising past papers; however, experience suggests that this approach does not usually produce good results, and that confidence in practical work will be greatly enhanced by a wider variety of practical experience. Similarly for Paper 5, it might be argued that planning, analysis and evaluation could be taught theoretically. However, without hands-on experience of manipulating their own data, putting their plans into action and evaluating their own procedures and results, students will find this section difficult and will be at a distinct disadvantage in the examination. Those students who

achieve the highest grades do so because they can draw on personal experience, and so are able to picture themselves performing the procedure they are describing, or recall analysing their own results from a similar experiment. Students with a bank of practical experience are much more likely to perform well than those with limited practical skills.

What are the practical skills required by this course?

The syllabus specifies the practical skills to be assessed by providing generic mark schemes for the practical papers. These mark schemes divide practical skills into four broad areas.

- Manipulation, measurement and observation AS
- Presentation of data and observations AS
- Analysis, conclusions and evaluation AS and A2
- Planning A2

For teaching purposes, it is helpful to subdivide the first and third of these broad areas into slightly narrower ones. Students will also find it helpful to think about the sequence in which practical skills are used in a typical scientific investigation.

This course addresses practical skills under seven headings that contribute to the overall understanding of scientific methodology. In a scientific investigation these would be applied in the following sequence.

- 1 Planning the experiment**
- 2 Setting up and manipulating apparatus**
- 3 Making measurements and observations**
- 4 Recording and presenting observations and data**
- 5 Analysing data and drawing conclusions**
- 6 Evaluating procedures**
- 7 Evaluating conclusions**

It is easy to see how these seven skills are related to the four areas in the syllabus.

The emphasis of the AS part of the course is on skills 2, 3, 4, 5 and 6. In other words, students have to master the basic skills of manipulating apparatus, making measurements, displaying their data in tables and on graphs, and drawing conclusions. They also have to learn to critically evaluate the experimental procedures by identifying limitations and sources of error and by suggesting improvements.

The A2 syllabus concentrates on skills 1, 5 and 7 – the higher-level skills of planning, data analysis and evaluation. All of the skills developed in the AS part of the course are assumed to have been mastered and skill 5 is extended and deepened. The A2 skills can only be developed by allowing students to take a greater degree of control over the procedures they use in practical classes.

Summary of each of the seven skills

Full details of the requirements for each of these skills may be found in the syllabus. What follows below is a brief summary of the skills involved.

1 Planning

- **Defining the problem**

Students should be able to use information provided about the aims of the investigation, or experiment, to identify the key variables.

- **Methods of data collection**

The proposed experimental procedure should be workable. It should, if the apparatus were to be assembled appropriately, allow data to be collected without

undue difficulty. There should be a description, including clear labelled diagrams, of how the experiment should be performed and how the key variables are to be controlled. Equipment, of a level of precision appropriate for the measurements to be made, should be specified.

- **Method of analysis**

Students should be able to describe the main steps by which their results would be analysed in order to draw valid conclusions. This may well include the proposal of graphical methods to analyse data.

- **Safety considerations**

Students should be able to carry out a simple risk assessment of their plan, identifying areas of risk and suggesting suitable safety precautions to be taken.

2 **Setting up and manipulating apparatus**

Students must be able to follow instructions, whether given verbally, in writing or diagrammatically, and so be able to set up and use the apparatus for experiments correctly. They will need to be able to work with a variety of different pieces of apparatus and to work from circuit diagrams.

3 **Making measurements and observations**

Whilst successfully manipulating the experimental apparatus, students need to be able to make measurements with accuracy and/or to make observations with clarity and discrimination. They may need to be able to use specific measuring instruments and techniques, such as Vernier scales, cathode-ray oscilloscopes, or Hall probes. They need to be able to manage their time while they make measurements, and to be able to make decisions about when it is appropriate to repeat measurements. They need to organise their work so that they have the largest possible range of readings and so that the readings are appropriately distributed within that range. They should be able to identify and deal with results which appear anomalous.

4 **Recording and presenting observations and data**

Observations, data and reasoning need to be presented in ways that are easy to follow and that accord with conventional good practice.

- **Tables of results**

The layout and contents of a results table, whether it is for recording numerical data or observations, should be decided before the experiment is performed. 'Making it up as you go along' often results in tables that are difficult to follow and don't make the best use of space. Space should be allocated within the table for any manipulation of the data that will be required. The heading of each column must include both the quantity being measured and the units in which the measurement is made. Readings made directly from measuring instruments should be given to the number of decimal places that is appropriate for the measuring instrument used (for example, readings from a metre rule should be given to the nearest mm). Quantities calculated from raw data should be shown to the correct number of significant figures.

- **Graphs**

Students should label the axes of their graphs clearly with the quantity, unit and scale all clearly shown in accordance with conventional good practice. Scales should be chosen so that the graph grid is easy to use and so that the plotted points occupy the majority of the space available. All of the points in the table of results should be plotted accurately. Students should be able to draw curves, tangents to curves or lines of best fit.

- **Display of calculations and reasoning**

Where calculations are done as part of the analysis, all steps of the calculations must be displayed so that thought processes involved in reaching the conclusion are clear to a reader. Similarly, where conclusions are drawn from observational data, the key steps in reaching the conclusions should be reported and should be clear, sequential and easy to follow.

5 Analysing data and drawing conclusions

Students should be able to calculate the gradient and intercepts of a line, including finding the intercepts when a false origin has been used on the graph. They should be able to use these to find the equation of the line of best fit through their points. They should be able to relate an equation predicted by theory to the equation of their line of best fit or to their data, and hence to find the values of constants or to draw conclusions about the veracity of the theoretical prediction. They should be able to use the idea of proportionality in their reasoning. They should be able to make predictions or hypotheses based on their data.

In the AS part of the course, students would normally be told what quantities to calculate, what graph to plot and would be led through the analysis. In the A2 part of the course, students would normally be expected to be able to plan the analysis for themselves. This would normally include deciding what quantities to plot in order to obtain a straight-line graph, deciding how to calculate these quantities from their raw data, and deciding how to reach a conclusion from their graph.

6 Evaluating procedures

Students should be able to identify the limitations and weaknesses of experimental procedures. To be able to do this effectively, they must have a clear idea of the purpose of the experiment, and they must have carried out the procedure for themselves. They should be able to make reasonable estimates of the uncertainties in the quantities they have measured directly, and to compare these so that they can identify the largest sources of error. They should be able to suggest improvements to the experimental procedure which would improve the accuracy or reliability of the experiment.

7 Evaluating conclusions

This skill is primarily concerned with the treatment of errors. Where the outcome of an experiment is the value of a constant, the treatment of errors should lead to an estimate of the uncertainty in the student's value. Where the experiment is a test of a hypothesis, the treatment of errors should allow the student to discuss the validity of their conclusion in terms of the precision of the experimental procedures.

As part of the treatment of errors, students should be able to make estimates of the uncertainties in their measurements, calculate the uncertainties in derived quantities, display error estimates in tables of results, plot error bars on their graphs, and estimate the uncertainties in their calculations of gradients and intercepts.

A sequence for introducing the skills

The above list shows the seven skills in the order in which they would be used in an extended investigation. It is not suggested that these skills should be taught in this order (although students will find it helpful to understand how the skills fit together in an investigation).

Students who are new to practical work will initially lack the basic manipulative skills, and the confidence to use them. It would seem sensible, therefore, to start practical training with skills 2 and 3, initially with very simple tasks and paying attention to the establishment of safe working practices. These short initial exercises should focus on training students in setting up

common items of apparatus (such as power supplies and stands, bosses and clamps) and in the use of simple measurement techniques (such as the use of rules, stopwatches and electrical meters).

Once a measure of confidence in their manual dexterity has been established, AS students can move on to exercises that require skills 4 and 5 to be included. The exercises should be simple at first and grow in complexity. Extensive experience in carrying out practical procedures allows students to gain awareness of appropriate quantities and to become more organised in the management of time and the recording of data as it is collected.

It is likely that skill 6, Evaluating Procedures, will be the most difficult to learn at AS level. Critical self-analysis does not come easily to many people. 'My experiment worked well' is a common – and inadequate – student evaluation of an experiment. If students are to master this skill, they need to begin by developing an appreciation of the reliability and accuracy inherent in the equipment and procedures they are using. Exercises with less reliable outcomes can be used to provide more scope for the evaluation of procedural, technical or apparatus weaknesses.

In the AS year, most practical tasks will include instructions on what apparatus to use, how to set it up, what data to collect, and what graphs to plot. The skills under development in the AS year are concerned with being able to carry out these tasks effectively, and to evaluate what they have been asked to do. In the A2 year, students should begin to take more control over decision-making. This will include some exercises to develop skill 5: such exercises might provide instructions on what apparatus to use and what data to collect, but leave students to decide on how to conduct the analysis of their data, including decisions about what graph to plot. Practical work at this stage will also include some exercises to develop some aspects of skill 1, for example by telling students what data they need to collect but requiring them to decide how to collect it with the apparatus provided.

The evaluation of conclusions, skill 7, is essentially about the propagation of errors. This requires a high degree of familiarity not only with the basic ideas of uncertainty in measurements but also with the analysis of experimental data, and so is an A2 skill. This skill should be introduced early in the A2 year and students should then regularly be required to practice their skill with the treatment of errors.

Planning is arguably the most demanding of the seven skills. For it to be effective, students need to be very well grounded in skills 2-6, so that they can anticipate the different stages involved in the task, and can provide the level of detail required. It is for this reason that planning skills are not assessed at AS level but form part of the A2 assessment. Candidates cannot be taught to plan experiments effectively unless, on a number of occasions, they are required:

- to plan an experiment;
- to perform the experiment according to their plan;
- to evaluate what they have done.

Ways of doing practical work

Physics teachers should expect to use practical experiences as a way to enhance learning. Practical activities should form the basis on which to build knowledge and understanding. They should be integrated with the related theory, offering opportunities for concrete, hands-on learning rather than as stand-alone experiences. In planning a scheme of work it is important to consider a mosaic of approaches that include those that allow students to participate in their own learning.

- Some practical activities should follow the well established structure that includes a detailed protocol to follow. Such well-structured learning opportunities have a vital role to play in introducing new techniques.
- Other practical activities should offer the students the opportunity to devise their own plan and to apply their plan to solving a problem. The excitement generated by such autonomy provides a stimulus to engage a student's interest and challenge their thinking.

Practical activities may be used as a tool to introduce new concepts – for example by investigating the properties of new circuit components or of pieces of polaroid, followed up by theoretical consideration of the reasons for the results obtained. On other occasions, practical work can be used to support and enhance the required knowledge and understanding – for example in building upon a theoretical consideration of diffraction with a series of practicals involving light, water waves and microwaves. In all cases, learning will be enhanced most effectively by practical work that encourages students to be involved, to think, and to apply and use their knowledge, understanding and skills.

There are many strategies by which practical work can be integrated into a scheme of work. Teachers should use a variety of methods. Some of the ways of delivering practical work enable the teacher to interact on a one-to-one basis with individual students, which allows a teacher to offer support at a more personal level and develop a greater awareness of an individual student's needs.

The choice of the specific strategy to use will depend on such issues as class size, laboratory availability, the availability of apparatus, the level of competence of the students, availability and expertise of technical support, the time available, the intended learning outcomes for the activity and safety considerations. The following are some possible strategies for delivery of practical work:

- **Teacher demonstrations**

Teacher demonstrations require less time than full class practicals, but give little opportunity for students to develop manipulative skills or gain familiarity with equipment. Careful planning can give opportunity for limited student participation. Teacher demonstrations are a valuable way of showing an unfamiliar procedure at the start of a practical session, during which students go on to use the method themselves.

Considerations when deciding whether to do a teacher demonstration might include:

- i **Safety** – some exercises carry too high a risk factor to be performed in groups.
- ii **Apparatus** – complicated procedures or those using limited resources.
- iii **Time** – demonstrations usually take less time.
- iv **Outcome** – some results are difficult to achieve and may be beyond the skill level of most of the students. A failed experiment may be seen as a waste of time.
- v **Students' attention** – a danger is that the attention of some students will drift.
- vi **Manipulative experience** – the teacher gets experience, the students don't.

There are many good reasons for the teacher performing a demonstration but do be aware that most students have a strong preference for hands-on experimentation. So, where possible, do let them do it!

- **Group work**

Whole class practical sessions. These have an advantage in terms of management as all the students are doing the same thing. Students may be working individually, in pairs or in small groups. Integrating this type of practical is straightforward as lessons beforehand can be used to introduce the context and following lessons can be used to draw any conclusions and to develop evaluation. Where specialised equipment or expensive materials are in short supply this approach may not be feasible.

Small group work. This can provide a means of managing investigations that test a range of variables and collect a lot of measurements. Although the same procedure may be performed, each small group of students collects only one or a few sets of data which are then pooled. The individual student has the opportunity to develop their subject specific skills. Part of the role of the teacher is to monitor and maintain safety and also to enable and persuade reluctant learners to take part. Group work aids personal development as students must interact and work co-operatively.

Considerations when deciding whether to do group work might include:

- i **Learning** – successful hands-on work will reinforce understanding; also, students will learn from each other.
- ii **Confidence** – this will grow with experience.
- iii **Awareness/insight** – should grow with experience.
- iv **Team building** – a most desirable outcome.
- v **Setting out** – all students doing the same thing is easier for the technicians.
- vi **Confusion** – incomplete, ambiguous or confusing instruction by the teacher will waste time while the instructions are clarified but may also compromise safety and restrict learning.
- vii **Opting out** – some students will leave it for others to do and so learn very little.
- viii **Safety** – constant vigilance is essential.
- ix **DIY** – the urge to adapt their experiments, to ‘see what would happen if’, must be strictly dealt with.
- x **Discipline** – practical time must not be allowed to become ‘play time’.

Working in groups, whether as part of a whole-class situation or where groups are working on parts of a whole, is probably the preferred option for many students. At A level, it is highly desirable to include opportunities for students to work on their own, developing their own skills and independence. In the examination, a student’s practical skills will be assessed on an individual basis, so an individual’s experience, competence and confidence are of considerable importance.

- **Circus of experiments**

A circus comprises of a number of different exercises that run alongside each other. Individuals or groups of students work on the different exercises and, as each exercise is completed, move on to the next one. These are a means by which limited resources can be used effectively.

There are two basic approaches. Firstly, during a lesson a number of short activities may be targeted at a specific skill. Alternatively, over a series of lessons, a number of longer practical activities are used, addressing a variety of skills. The circus arrangement may

be more difficult to manage as the students are not all doing the same activity. This puts more pressure on the teacher as they have to cope with advising and answering questions from a variety of investigations. With circuses spread over a number of sessions, careful planning is needed to enable the teacher to engage each group of students and to maintain a safe environment. In these situations it is useful to have a few of the circus activities that involve no hands-on practical work, using data response based simulations or other activities. In this way the teacher can interact with groups that need a verbal introduction or short demonstration and can monitor their activities more effectively.

Considerations when deciding whether to do a circus of experiments might include:

- i **Apparatus** – if the amount of apparatus used in an exercise is limited, students are able to use it in rota.
- ii **Awareness** – students by observing their peers will become more aware of the pitfalls of the exercise and so will learn from the experience of others.
- iii **Safety** – different exercises may well carry different safety risks, all of which would need to be covered.
- iv **Setting out** – students doing different exercises will make it more difficult for the technicians.
- v **Opting out** – some students may be tempted to ‘borrow’ the results of earlier groups.

- **Within theory lessons**

This option should be considered whenever it is viable. It is likely that the practical work would be by demonstration, as this would take less time. Given the power of visual images, the inclusion of a short practical to illustrate a theoretical point will reinforce that point and so aid the learning process. It is critical, however, that the practical works correctly, otherwise the flow of the lesson is disrupted and confidence in the theory may be undermined. The exercise should therefore be practiced beforehand.

- **Project work**

Projects are a means by which a student’s interest in a particular topic, which is not always directly on the syllabus, can be used to develop investigative skills. This sort of investigative work can be individual, or a group activity. Once the project is underway, much of the work can be student-based, although if it is practical it needs to be undertaken under the supervision of the teacher for safety reasons. Care is needed in selecting the topics and setting a time scale, so that the relevance is maintained to the syllabus context.

- **Extra-curricular clubs**

The role that these can play is in stimulating scientific enquiry methods. There are a number of ways of using clubs. One way is to hold the club session during the teaching day so that all students can attend. In effect this becomes additional lesson time in which students can practice investigative skills, including laboratory work. Such laboratory work involves materials that have a cost, which must be planned for beforehand. If however the club is held outside the teaching day it may be voluntary. Syllabus-specific activities should be limited and the most made of the opportunities for exciting work unrelated to syllabuses. Students who do attend the club could be used as a teacher resource by bringing back their findings to a classroom session.

Keeping records

Students often find it a problem to integrate the practical work and the theory. This is particularly true when a circus of experiments or a long-term investigation or project is undertaken. Some potential issues include:

- Some students use odd scraps of paper in the laboratory, which are lost or become illegible as water is spilled on them. One important criterion is that students are trained to immediately and accurately record results.
- Practical procedures may be provided on loose sheets of paper which are subsequently lost, or students write down the results from a teacher demonstration. In either situation, students end up with results but no procedure or context.
- When results take a period of time to collect, analysis becomes isolated from the context of the investigation and may not be completed.

The key to minimising these issues is to train students into good working practices. This is particularly important in colleges where students join at the start of their A levels from a variety of feeder schools. It is also vital for students with specific learning difficulties that affect their ability to organise their work such as dyslexia and Asperger's syndrome.

Students may be encouraged to integrate the practical in the same file as the theory. Alternatively, students may be encouraged to keep an entirely separate practical book or file. Loose leaf files make it easy to add to the file, but may make it easier to mix up or lose items. Exercise books can be used but students should be encouraged to glue worksheets and their laboratory records into the book so that they are not lost. Depending on how they learn, individuals may vary in their preferred method. Whichever option is chosen, students need to be encouraged to relate their investigations to the appropriate theory and to regard it as something that needs to be thoroughly assimilated.

- Integrating the materials generated by practical work with the notes and other items from the learning of theory can be achieved by interspersing the records of investigations with the relevant section of theory. This may still require cross-referencing where several learning outcomes and assessment objectives are targeted by work.
- Keeping a separate practical book enables records of all the practical investigations to be kept in one place. Students need training to manage practical files effectively, particularly in keeping the contexts and cross referencing to the theory. If care is not taken to develop and keep up these skills, students may perceive practical work as something entirely different from theory.
- An intermediate between these two extremes is having a separate section for practical investigations in each student's file with each syllabus section and cross referenced to the relevant theory.

How is a practical activity organised?

Preparing for practical work needs thought and organisation. The practical work may be an activity that forms part of a lesson, it may comprise an entire lesson, or it may be an investigation designed to last for several lessons. In every case, thorough preparation is a key prerequisite to success.

Practical and investigative work should be integrated into the programme of study. The scheme of work should identify appropriate practical investigative experiences for use at the most suitable time. In designing the scheme of work,

- the resource implications should be considered in terms of equipment and materials in stock,
- the time taken from order to delivery and the cost of materials to be obtained from suppliers should be considered,
- careful scheduling may be needed in Centres with a large number of students. It may be possible to permit several groups to do the work simultaneously or in quick succession, or it may be essential to re-order the scheme of work for different groups so that scarce resources can be used effectively,
- note must be taken of national or local health and safety regulations relating to laser light, high voltages, chemicals etc. There may also be regulations controlling the use of radioactive sources.

Once the scheme of work has been established, the next stage is to consider each practical activity or investigation. In an ideal course, each of the following stages would be gone through in developing each practical exercise in a course. This is not always realistically possible the first time through a course, and in such circumstances it is better to get some practical work done with students than to hold out for perfection before attempting anything. Obviously, all practical work should be subject to careful and rigorous risk assessment, no matter how provisional the rest of the supporting thinking and documentation may be.

- Decide on the aims of the work – the broad educational goals, in terms of the practical skills involved (e.g. evaluating procedures) and the key topic areas (e.g. Motion in a Circle).
- Consider the practical skills being developed. Reference should be made to the syllabus, which in the Practical Assessment section includes learning outcomes relating to practical skills. For instance, if the practical work is intended to be a planning exercise, which of the specific skills identified in the learning outcomes will be developed?
- With reference to the topics included, decide on the intended learning outcomes of the practical activity or investigation, again referring to the syllabus. For instance, which of the “Capacitance” learning outcomes will be achieved? In some cases during the course, the material on which the practical is to be based may be unfamiliar, in which case there may be no topic-related intended learning outcomes. Thus, A2 contexts may be used for AS practicals, and topic areas not on the syllabus at all may be used for AS or A2 practicals.
- In addition, it is useful to assess any other context of the practical work investigation. For instance, is it intended as part of the introduction of a concept, or to support a theory, or to demonstrate a process?
- Produce a provisional lesson plan, allocating approximate times to introduction, student activities and summarising.

- Produce and trial a student work sheet. Published procedures or those produced by other teachers can be used. Alternatively produce your own. As a rule, schedules produced by others need modifying to suit individual groups of students or the equipment available. It is helpful to ask students or another teacher to read work sheets before they are finalised as they can identify instructions that are ambiguous or that use inaccessible terminology.
- Refine the lesson plan in relation to the number of students for which the investigation is intended (whole class or a small group), the available equipment (does some have to be shared?) and materials. There are examples of lesson plans and student work sheets in Appendix 2.
- Carry out a detailed and careful risk assessment before any preparatory practical work is done, and certainly well before students do any of the practical work. You should consider
 - the likelihood that any foreseeable accident might occur,
 - the potential severity of the consequences of any such accident,
 - the means that can be taken to reduce the severity of the effect of any accident.
- Make an equipment and materials list. This should include
 - apparatus and materials (including quantities) per student or per group,
 - shared equipment per laboratory (e.g. sinks, top-pan balances),
 - the location of storage areas for equipment and materials.
- Set up and maintain a filing system where master copies of the work sheets, lesson plans and equipment lists can be stored. It is helpful to have these organised, or at least indexed, in both their syllabus context and skills developed.
- Once an investigation has been used by a group of students it should be evaluated in relation to intended outcomes and the lesson plan. It is important to obtain feedback from the students about their perception of the work. For example,
 - was the time allocation appropriate?
 - were the outcomes as expected?
 - did the students enjoy the work?
 - did the students understand the instructions?
 - was the point of the work clear to the students?

If necessary the work sheet and lesson plan should be revised.

Teaching A2 skills

The feel of practical work in the A2 year

It may be thought by some that, as there is not a practical exam at the end of the A2 year, practical work is not needed. **THIS IS NOT THE CASE.** In order to prepare students fully for the final examination, practical work is absolutely essential. There are many reasons for this but the two most fundamental ones are as follows.

- To support and illustrate theory that is covered in the lessons. Students can find some of the ideas in the course abstract and hard to imagine. Demonstrations and practical work provide an essential opportunity for students to ‘see’ what they are learning and will inevitably reinforce and strengthen their understanding.
- Although the exam itself is not practical, the single best way to develop the skills needed for it is through regular structured, targeted practical activities.

It is critical that students are given multiple opportunities to develop and refine their planning and evaluating skills before the final examination. Whilst Paper 5 itself does not involve practical work, by far the best way to prepare for the examination is to learn by planning and actually carrying out experiments. By doing this, they will inform their understanding of what works, what doesn’t work, and ways in which potential problems can be avoided or overcome.

Some of the practicals described in Appendix 2 of this booklet are designed to be much more open ended than those in the companion AS booklet. In most cases, suggestions for more detailed guidance are included. The first time that a more open-ended activity is done with the students, some students will not feel comfortable with having to take more control of what they do, and it may be necessary to give them additional guidance. However, their confidence should grow quickly with their skills and it is to be hoped that very quickly they will become more confident with a more open way of working. It is strongly recommended that the amount of guidance given to students is kept to a minimum.

It is important that students understand what constitutes a successful practical. A practical has been successfully carried out if the results that the students obtain, the written work that they produce, the justifications for what they did and explanations of what they found are of a high quality and demonstrate the right practical skills. Many students assume, quite wrongly, that the sole purpose of a practical exercise is to “get the right answer”. Teachers need to be alert to this and to encourage a more sophisticated approach where necessary.

It is also important to stress that, in more open investigations, there may not be just one right way to do things. It is quite possible that several different approaches are of equal value.

Extending AS practical skills for the A2 year

The practical sessions in the A2 course will build on the skills that have been developed during the AS part of the course. It is important that the students feel that all that they have learned on the AS course will continue to be of value and use to them.

The students will come into contact with different and possibly more complicated apparatus. For example, the need to be familiar with the use of a calibrated Hall probe is specifically mentioned in the syllabus, and this is addressed in one of the practicals in Appendix 2 of this booklet. During the A2 year of the course, the students should be gaining confidence in using a wider variety of equipment, and in setting up apparatus with little or no help or guidance.

One of the AS practical skills that will need development in the A2 year is the appreciation of the importance of equations in the form $y = mx + c$. They will need to understand how to select variables to plot on their graphs in order to obtain straight lines. For example, in the

investigation of a mass oscillating on a spring, the equation relating the period T to the mass m is

$$T = 2\pi \sqrt{\frac{m}{k}}$$

where k is the spring constant. Given this equation, students need to recognise that a graph of T^2 against m or T against \sqrt{m} will produce a straight line that passes through the origin, and they will need to be able to relate the gradient of the line to k .

Students will also need to be able to manipulate equations by taking logarithms of both sides in order to create an equation in the form $y = mx + c$. For example, the exponential decay of charge Q on a capacitor of capacitance C through a resistance R is given by the equation

$$Q = Q_0 e^{-\frac{t}{RC}}$$

where Q_0 is a constant and t is time. Students will need to be able to recognise the form of this equation, take natural logarithms of both sides and rearrange to give

$$\ln Q = \frac{-1}{RC} t + \ln Q_0.$$

From this, they will need to be able to recognise that a graph of $\ln Q$ against t will give a straight line and to interpret the gradient and the y -intercept of this graph.

Similarly they will need to be able to rearrange equations of the form

$$y = ax^n$$

and hence to plot a graph of $\lg y$ against $\lg x$ to find the values of a and n .

To teach students the necessary skills, they should be shown how to rearrange a few sample equations. They should then be given practice, in written exercises, of rearranging equations into a linear form. The skill acquired in this way should then be reinforced by further practice in practical work.

Some of the content of the syllabus is difficult or even impossible to investigate practically in a laboratory, perhaps because of legal restrictions on the use of radioactive substances in schools or because equipment is unavailable for other reasons. In such cases, computer-based simulations can be a useful way to demonstrate the ideas and allow students to see how variables are related to each other. However, simulations should never be seen as a satisfactory substitute for hands-on practical work.

Teaching students to plan experiments

A major focus of the A2 course is the ability to design experiments. Half of the marks for Paper 5 are awarded for this skill.

Much of the groundwork for teaching this skill should have been laid during the AS year of the course. During this year, students will have become familiar with most of the basic items of equipment in a Physics laboratory, and they will have become confident in using this equipment. They will have become familiar with the basic structure of most experiments – setting up apparatus, making and recording measurements, plotting graphs, and reaching conclusions. They will have learned to evaluate the procedures that they have been told to follow, including identifying the factors that reduced the accuracy of the experiment and making suggestions for improvement.

To develop this groundwork into an ability to plan experiments for themselves, students will need:

- to be helped to work with progressively less help, guidance and support;
- to evaluate and reflect on what they have done;
- to learn to assess the risks to themselves and others and to work safely;
- to learn to set their plans down in writing in a way that makes sense to another person;
- to extend the range of equipment with which they are familiar and comfortable.

These areas of competence need to be developed together, rather than sequentially, and they need to be developed over a period of time.

1. Help, guidance and support

If students have been accustomed to being given explicit instructions, then some of them may feel a little isolated and confused when they are given a more open brief. Some may find it very difficult to get started at all. The development of the confidence to work without guidance should be seen as a year-long process: most students will not be able to switch suddenly from detailed instructions to no instructions at all. Whilst students should always be pushed and stretched in their work, they also need time to develop their competences.

A staged approach to working without guidance is suggested. In the first term of the A2 year, most practical activities should have some element of guidance. This guidance might tell them what method to use to collect their data but ask the students to decide how to analyse the data. Alternatively, students could be told what data to collect but be required to decide how to set up the apparatus. Or perhaps they could be given details of how to set up the apparatus and what graph to plot, but they could be required to decide what data to collect.

In the second term, students should be given less and less guidance, until they are planning the whole experiment for themselves and carrying out their plan.

A staged approach will allow students to carry out practical activities in a structured way and will at the same time develop their decision-making skills. Inevitably, they will make some poor decisions. Some less confident students need to make mistakes with small decisions before they develop the courage to make larger decisions. With encouragement from their teacher, even reluctant experimenters can learn that poor decisions are not catastrophic, and that the freedom to be creative is exciting and liberating rather than stressful. Perhaps one of the most important ideas that should be stressed to the students is how important the making of mistakes is to the learning process: it is one of the best ways to truly inform what we do next time.

If they are used to very precise instructions, students can take the view that for any given experiment then there is only ever one right way to do any experiment. They should be encouraged to try different approaches, to measure things in different ways and to look at different ways in which a particular investigation could be done. This is very important because it allows them to start critically evaluating one method of doing something compared to another. This weighing of alternatives is an important thought process in the planning of experiments.

Many of the student worksheets in Appendix 2 of this booklet have only limited instructions for the students. Suggestions for more detailed advice, which can be given if necessary, are included in the teaching notes. This has been done deliberately so that, as some students develop, they can be given a freer rein to experiment themselves. For example, the Cantilever experiment that is detailed in Appendix 2 of this booklet is very open ended and potentially offers students a great deal of freedom and scope to investigate multiple patterns. The success of an investigation such as this is maximized only when the students feel confident in their own skills. This tends to come more towards the second half of the A2 year.

2. Evaluating and reflecting

Hindsight is a wonderful thing and can be used as a valuable teaching tool.

In their AS year, students will have learned to evaluate the procedures that they have been told to follow, identifying weaknesses and suggesting improvements. These skills are vital to the learning of planning skills. When students are asked to plan all or part of an experiment, they should carry out their plan and then evaluate what they have done. In the carrying out of the experiment, they will encounter difficulties or weaknesses that they had not anticipated. In their evaluation, they can consider these difficulties and weaknesses and reflect on how they could have done the work differently. The evaluation will consolidate the lessons of experience and will help to inform their planning the next time they encounter a similar issue.

Student worksheets should require an evaluation in all practical work where students have had to make decisions or plans.

3. Working safely

In any environment, safety considerations are crucial. Every time an experiment is carried out, a risk assessment should be carried out beforehand by the teacher. Where the work is more open, and students are making decisions about what to do, teachers need to be particularly careful to supervise the work of all students.

Where work is more open and students are making decisions about what apparatus to use and how to use it, the students themselves need to consider the risks to themselves and others. This risk assessment by the students should always be written down, should always be done before any work is carried out, and should include steps that can be taken to minimise any risks. By making such risk assessments routine, students become accustomed to thinking about risks, and will start to do it automatically. It may be worth pointing out to the students that the planning question in Paper 5 will always contain a mark for safety considerations.

In the case of class demonstrations by the tutor, it can be a valuable exercise to make the students carry out a risk assessment; even it is just orally, before the demonstration begins. Such an exercise is a good way to introduce the idea of risk assessment, early in the first term of the A2 year, before making it a routine part of practical work.

4. Setting plans down in writing

The idea of writing things down clearly and fully in advance is a crucial habit to develop. Often students will have a reasonable idea as to what they want to do. They will collect the equipment and then some can just stumble into the experiment. They need to be taught that a good plan is one that is clear and detailed and, most of all, clear enough so that someone else can follow it.

When given a more open brief with practicals, students may need to choose the equipment that they wish to use. From an early stage in the A2 year, some kind of ordering process may be used. It is suggested that, as preparation for a practical lesson, students should write an equipment list for the practical that they are planning. They could be asked to write a sentence or two against each piece of equipment, stating exactly what it is going to be used for and why it has been chosen. They should include details such as the ranges of meters. This will encourage clear thinking about the work to be done before the hands-on practical work begins.

Students can be encouraged to use a standard format for their plans. This will help them not to miss out key parts of their plan. The format could consist of a standard set of headings, such as:

- apparatus requirements,
- diagram and description of set up,

control of variables,
 how to vary and measure the independent variable,
 how to measure the dependent variable,
 method of analysis,
 safety considerations.

Even with brief sections, a plan written under these headings is likely to score a good mark in the examination.

Another approach is to give the students an experiment to plan, and requiring them to write the plan down. The students then exchange plans and attempt to carry out each other's plans. Finally, the students get together to reflect on the difficulties that they encountered. This approach requires the students to be comfortable with planning a whole experiment and is probably not appropriate until the second half of the year.

5. Extending the range of familiar equipment

Practical work in the A2 year will include syllabus areas that were not part of the AS course and, as a result, students will encounter new pieces of equipment. Familiarity with a wide range of equipment is useful to students who are answering planning questions in examinations. Each new piece of equipment is like a new tool in the student's mental toolkit and can be used to unlock a different set of problems. The scheme of work for the year should include introducing students to new equipment in a planned way.

Some students have a tendency to say that they fully understand how to use a piece of equipment when in fact their understanding is only partial. One effective way to improve their understanding is to ask them to write an introduction or 'user's guide' to each new piece of apparatus. Writing a user's guide forces them to make sure that they fully understand, and is most effective when students have just used a new piece of equipment for the first time or when they have just been introduced to it.

Some pieces of equipment may be unavailable to teachers. Radioactivity is firmly within the theory syllabus, and past examination papers have asked planning questions in the context of radioactivity. But radioactive sources are not legally permitted in schools in some countries and therefore detectors are unlikely to be found. Similarly, past examination papers have expected students to be familiar with the idea that vacuum pumps can be used to evacuate enclosed spaces and that the pressure can be measured with a pressure gauge, yet few schools have either vacuum pumps or pressure gauges. Teachers need to consider how to introduce students to pieces of equipment which are not available in the school laboratory but which would enable students to design different types of experiment. Possible approaches include the use of video material or computer simulations.

Where pieces of equipment are not available, some paper-based planning activities can be given to students to reinforce their understanding of how these items can be used. However, this paper-based approach is only recommended where equipment is unavailable. It should only be used sparingly to supplement the main, hands-on approach to the teaching of planning skills.

Teaching students to evaluate conclusions

Apart from planning, the other main focus of the A2 practical course is the evaluation of conclusions. In the examination, the question assessing this area will contain a minimum of structure and guidance. This means that, when this skill is being taught, students will need to learn to work with less structure than they were accustomed to in their AS year. This gradual reduction in the structure and support for students is therefore a feature of the whole A2 practical course, not merely of the planning aspect of the course.

Much of the groundwork for the A2 work should already have been laid during the AS year. Students should already be familiar with estimating errors in their measurements; converting between absolute and percentage errors; presenting data in tables of results; plotting graphs and drawing lines of best fit; calculating gradients and y -intercepts from straight-line graphs; relating graphs to formulae in the form $y = mx + c$ and calculating the values of constants from their gradient or y -intercept.

All of these skills will be used and extended as students learn to evaluate conclusions during the A2 year. At the beginning of the year, after the school holidays and before any new teaching starts, it may be a good idea to set some practical work which reminds students of these skills and reinforces them.

In many Physics practical activities, the objective of the experiment is to find the value of a constant. The purpose of the A2 work on evaluating conclusions is to enable students to find the error (i.e. the uncertainty) in the value of the constant. To do this, they will need to master several stages:

- determining error estimates for calculated quantities using the error estimates in their measurements;
- displaying error estimates in tables of results;
- displaying error estimates as error bars on graphs;
- making error estimates for the gradient and y -intercept of a graph;
- determining error estimates in the final constant using the error estimates in the gradient or y -intercept.

Although these are all necessary stages leading towards the same goal, it would be a mistake to try to teach everything at once. It would be too much for most students to absorb at the same time. Instead, each stage needs to be taught separately and internalised by the students before the next stage is attempted. As each stage is taught, the students will need to be shown that it has a purpose: if it appears to be pointless, the students will find the work de-motivating. This is challenging for the teacher because it is not until all of the stages have been taught that students can see that they all belong together. The sequence in which different skills are taught is therefore important, and a suggested sequence is outlined below.

1. Revising AS level work on error propagation

Students will be aware from their AS practical work that there is an uncertainty in every measurement that they make, and that this uncertainty can be expressed in an absolute form or as a percentage. It will be necessary to point out to them that this uncertainty in the raw data leads to uncertainty in all values derived from that data. The attempt to quantify the uncertainty in derived quantities is called *error propagation*.

Students will have encountered a limited treatment of error propagation in their AS course when they covered learning outcome 2(f). This treatment is limited to the idea that the error in a derived quantity z may be found as follows:

if $z = xy$ or $z = \frac{x}{y}$, then

percentage error in $z = (\text{percentage error in } x) + (\text{percentage error in } y)$;

and if $z = x + y$ or $z = x - y$, then

absolute error in $z = (\text{absolute error in } x) + (\text{absolute error in } y)$.

These relationships may be reinforced at the beginning of the A2 year with a series of very short and imprecise whole class experiments. These could include, for example,

finding the density of wood (with its error estimate) using a rectangular wooden block. This activity involves multiplication (to find the volume) and division (to find the density). Different groups within the class can be given different measuring instruments (e.g. millimetre scales and top-pan balances or centimetre scales and a requirement to gauge the mass by comparing the feel of the block in the hand with known masses). This would give different groups different error estimates in their values for density. When all groups have calculated values for the density, with an absolute error, the values obtained can be compared with each other and with the density of water. Some groups may have uncertainties so large that they would not be able to predict whether the wood would float or sink. From this, students should be allowed to conclude that, wherever possible, experimentally-derived quantities should always have a numerical value **and** an error estimate **and** a unit. Without an error estimate, they can be seriously misleading. This point will need to be reinforced at regular intervals throughout the course.

2. Displaying error estimates in tables of results

In their AS year, students should have learned to estimate experimental errors, but they may not have been told to record them in their tables of results. Early in the A2 year, they should be instructed to record absolute error estimates beside every value in their table of results, including both columns of raw data that they have measured directly and columns of derived quantities that they have calculated from their raw data. It may be explained to the students that it is good practice always to show error estimates beside experimental values, and that it will be helpful for them to see the error estimates when they are evaluating the experiment and considering the major sources of error.

After this, students should be encouraged to include error estimates in all tables of results. Student worksheets may remind them about this for a while but later on the students should be expected to include error estimates automatically and without reminders.

3. Displaying error bars on graphs

Once students have grown accustomed to the idea that absolute error estimates should be included in tables of results, they can be taught to display the same information on their graphs by drawing error bars. As with many other practical skills, this is best taught by showing them how it is done, explaining to them why it is done, and then requiring them to use the technique immediately afterwards in their own practical work.

There are two advantages of drawing error bars on graphs which may be explained to the students. Firstly, when drawing the line of best fit, the line should pass through (or very close to) all of the error bars (it is helpful to ask the students to consider what it means if the line does not pass through or near the error bar of a data point). If the error bars are of different lengths at different points, then it is useful to be able to see this when drawing the line of best fit. Secondly, the error bars on a graph provide a very visual way of indicating how precisely the gradient and y -intercept of the graph may be known. With some data sets, even when the error bars are quite large, the scope for drawing a straight line that passes through all of them may be quite limited. Other data sets with the same sized error bars may allow a wide variety of straight lines that pass through all of the error bars.

Students should be able to plot a horizontal error bar and vertical error bar for every data point if necessary.

4. Determining the error in the gradient and the y -intercept of a line

Once students have become accustomed to drawing error bars on their graphs, they should be taught to determine the error estimates in the gradient and y -intercept of a line. The way that this should be done is by drawing, in addition to the line of best fit, a “worst acceptable line” through the data points.

The “worst acceptable line” is *acceptable* because, like the line of best-fit, it should pass through or near to all of the error bars. This means that it would be acceptable as a straight line that passes through the data points. However, it is the *worst* acceptable line because it is the steepest (or shallowest) of all the possible acceptable lines.

Clearly there are two possible “worst acceptable lines” – the steepest one and the shallowest one. Students only need to draw one and it does not matter which one they draw.

Students should then calculate the gradient of **both** the best-fit line and the worst acceptable line. The error is the difference between the best and the worst value. For example, if the gradient of the best fit line is 2.3 and that of the worst acceptable line is 2.7, then the gradient is equal to 2.3 ± 0.4 .

The same method may be used to determine the error in the y-intercept of the line.

With this method, students will draw two lines on each graph. It is important that these are distinguishable. The syllabus suggests that the worst acceptable line should either be labelled or drawn as a broken line.

Once students have been introduced to this method, they should be expected to use it in all subsequent practical work.

5. Propagating errors from the gradient or y-intercept to the final answer

The method used to do this is the same as the method used to propagate errors from raw data to calculated quantities and is described in section 1 above and in section 6 below. Once students are able to determine the errors in their gradients and y-intercepts, they should be encouraged to propagate these to their final answers.

6. More error propagation

Students should know from their AS level studies how to determine the errors in quantities that are calculated from other quantities by the basic arithmetic functions of addition, subtraction, multiplication and division (see section 1 above). For more complex mathematical functions, a different approach to error propagation is required. The approach is to find the “best” value and the “maximum” value, and is best illustrated by an example.

If $x = 7.2 \pm 0.6$, what is the uncertainty in $\ln x$?

The natural logarithm of the best value of x is $\ln 7.2 = 1.974$.

The natural logarithm of the maximum value of x is $\ln (7.2 + 0.6) = 2.054$.

The difference between these values is $2.054 - 1.974 = 0.080$.

Therefore $\ln (7.2 \pm 0.6) = 1.97 \pm 0.08$.

Two points are worth noting. Firstly, this approach can be used with any mathematical function, not just with natural logarithms. Secondly, it is conventional that the error estimate is normally quoted to one significant figure, and this should determine the number of significant figures in the derived quantity.

This approach may be introduced at any time after students have learned to record error estimates in tables of results, and immediately before a practical activity in which it can be used, so that the practical activity will reinforce what has been taught. Subsequent practicals should be chosen so that this technique is required from time to time and is used often enough not to be forgotten.

Designing a practical course for the A2 year

This booklet is designed as a guide to help and support teachers in the delivery of the course. It does not provide a complete course on its own and does not offer full coverage of every aspect of the syllabus in detail. Instead, it is intended to help equip teachers to plan and deliver a full, coherent course. It is intended to complement the resources and experience already existing in the Centre.

Appendix 1 of this booklet provides a list of suggested practical activities that could be used to help deliver a Physics practical course in the A2 year of A level. They are only suggestions: some of them may not be suitable for your Centre and so you may need to adapt them or select alternatives.

The activities in Appendix 1 are listed in syllabus order, that is, in the order in which the subject content (not the practical skills) are listed in the syllabus. The actual order in which these practical activities are carried out will depend largely on the sequence in which the theory is taught, so that theory and practical work support each other in the learning process. When considering an order for the practical activities, you will also have to consider the sequence in which you are introducing new practical skills and techniques. Some of the activities will need careful adaptation to ensure that they only require the skills that have already been introduced and that they include the practical skills that you want to reinforce at that time.

For each practical activity, it is suggested that the following documents are produced:

- a student worksheet (to tell the student what to do);
- teaching notes (specifying the objectives of the activity);
- technical notes (specifying the apparatus, materials and facilities required).

As examples of how practical activities can be worked up in this way, Appendix 2 takes ten of the practicals from Appendix 1 and provides all three documents for each. The intention of Appendix 2 is that it should demonstrate to teachers how practical activities may be worked up and equip them to do the same for the whole of their A2 level practical course.

Planning the course

The skills and techniques required of students are clearly laid out in the syllabus. When putting together a practical course, the syllabus should be used as a guide to ensure that the skills and techniques are all covered on at least one occasion (and hopefully more often).

When planning and preparing a course of lessons for the year, it is important to try and make sure that relevant practical activities are connected to the theory lessons and not just seen as an add-on. Practical work has a much greater strength if it is seen to complement and support the theoretical work covered in other lessons. Some practical skills may be introduced in one lesson and then developed or used in another lesson, building into a sequence. This helps to provide continuity for the students and to reinforce their learning.

By planning in advance it will be possible to select activities that run parallel with the content from the syllabus being delivered as well as providing a variety of different types of lesson. This will help to maintain students' interest and motivation.

When a practical activity requires a new skill, technique or piece of equipment, time needs to be set aside for this. This may mean that an extra activity needs to be included at the start of the lesson to prepare the students in advance. Alternatively it may be more appropriate to allow for extra time and support during that particular activity.

Using past exam papers

Past papers are available from CIE and can form a useful part of final exam preparation. However, Paper 5 is a written paper and, although the questions are useful in other ways, they are not generally suitable as a basis for hands-on practical activities in the school laboratory.

Past papers from earlier versions of the syllabus (i.e. from before 2007) or from other syllabuses may contain laboratory-based hands-on practical questions. However, these should be used with caution. As a means of illustrating content taught in theory classes they are often of limited use: they often touch on content from the syllabus but do not always deal with it as directly as the examples in Appendix 2. In addition, they are often poor vehicles for teaching practical skills: if they focus on the right skills (which most will not), then they are likely to require a high degree of familiarity with those skills. As such, if students are not totally confident with their skills and knowledge, they will be unlikely to be able to gain the full benefit from them.

Past exam papers should be seen less as a teaching tool but more as a valuable resource to be used at the end of the course as part of a structured revision program. They have a role to play in the reinforcement of the practical skills that have been covered and in the final preparation for the examination.

Planning lessons and teaching the course

In the teaching notes section of each practical activity in Appendix 2, there are detailed notes including clearly highlighted 'key learning objectives'. It is important that these objectives are stressed when the activity is being introduced and described to the students. Many students can carry out practical activities without fully understanding what they are doing and why they are doing it, and this inhibits their ability to learn from the experience. It is usually worth explicitly stating the key learning objectives to the students so that they have a clear focus for the lesson.

Although students will be involved in practical activity for most of the lesson, some lesson time should be spent on ensuring that each activity is properly introduced. The way an individual lesson is structured is very much up to the individual teacher but below is one possible approach to teaching practical activities.

Introduction (10 mins)

A teacher-led oral presentation which includes:

- An explanation of the activity that is to be carried out.
- A recap or explanation of the theory that relates to the practical. In many cases this will have been covered in more detail in a previous lesson.
- A description (and possibly a demonstration) of any equipment that is to be used or is needed in the practical. It is easy to make assumptions about what the students are confident with and this provides an opportunity to check before they start. If a new piece of equipment is to be used then the skills needed to use it must be directly taught. This may be done at this point but in some cases it is better to have provided a dedicated session at an earlier time.
- Safety. This should be raised before every single practical regardless of the risk. Students can be asked to make the risk assessment themselves and to make suggestions as to appropriate precautions (although each practical must have been risk assessed by a teacher beforehand).

Main activity (40 – 70 mins)

Each of the practical activities will take different amounts of time depending upon the students involved and the nature of the task. During this time some groups may well need support and help.

Where students are making decisions about how to conduct some or all of their experiment, they may need to take time at the beginning of the main activity to write down their plan, assemble the apparatus they need, or to experiment with different set-ups.

Students should always be encouraged to make one 'dry run' of a set of readings. They should consider the range of readings to be taken and whether repeat readings are needed. They should prepare the outlines of their tables of results.

Plenary (5 – 10 mins):

A teacher-led session where the main threads of the practical are brought back together. Some of the areas covered could include:

- A recap of the theory that underlies the activity and a reminder to cross-reference the practical work and the theory notes.
- A discussion of the practical skills and any particular equipment or techniques that were needed.
- A discussion of any limitations, errors or problems involved in the activity and ways in which these could be dealt with.
- A reminder of the expectations of the written work that will follow (which should be included in the student worksheets).

Planning for a circus

In many Centres, practical activities may be carried out as part of a circus. In this case it is not possible for an introduction to the activities to be held as a teacher-led plenary session at the start of each lesson, because there are too many activities taking place. However, the introduction of each activity is important and should not be lost: it helps the students to understand both what they are doing and why they are doing it. One possible solution to this is to hold a 'circus introduction session'.

For the first session of the circus, set up the laboratory so all the equipment for each of the activities is visible. Take the whole class round the laboratory introducing each experiment, using the introduction section above as a guide. Although this may take quite some time, this is a worthwhile thing to do and will hopefully allow each subsequent practical session to run more smoothly. It will give students a clearer idea of what they are required to do.

A possible alternative to this would be to run the first session without introducing the experiments. Give the students a very quick run-through and then issue the student worksheets. Let students know that, at the beginning of the next session, they will need to describe the key points to the rest of the class. Begin the next session with each group introducing to the rest of the class the activity they have done. If this approach is taken then this can act as a good way to get the students to develop their communication skills.

Appendix 1: Possible A2 practical activities

The table below lists a series of practical activities that can be delivered to both support the theory and to develop the students' practical skills. The activities are mapped against the learning outcomes in the theory sections in the syllabus and are listed in syllabus order.

Each practical activity should also be mapped against the practical skills required, partly to ensure that the skills and equipment are introduced at the correct points and partly to ensure that all skills are covered during the course. Many of the practical activities could be conducted in different ways to give emphasis to different skills, and therefore the mapping must be done when the details of the practical are worked out (i.e. when the student worksheets, teaching notes and technical notes are produced).

Suggestions have been made whether something is suitable as a demonstration or practical. In almost all cases it is possible for students to carry out experiments listed as demonstrations, although the experiments may need to be set up and tested beforehand.

Practical Name	Description / comments	Suitability for practical or demonstration	Link to syllabus learning outcomes
Displacement during circular motion	A thin object such as a pin or nail is stuck upright on the outside edge of a turntable. Behind the turntable is a large card/paper screen and on the other side of the turntable is a bright light such that the thin object causes a sharp shadow on the screen. The turntable is rotated; the angle of rotation measured as well as the horizontal displacement of the shadow to help relate SHM to circular motion.	Demonstration	7(a), 7(c), 14(e)

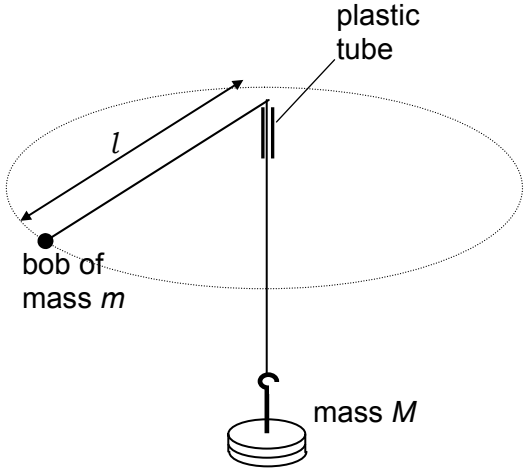
Practical Name	Description / comments	Suitability for practical or demonstration	Link to syllabus learning outcomes
Circular motion	<p>A small bob of mass m is placed on the end of a long string that is then passed through a stiff plastic tube that is long enough to be held in a hand. On the other end of the string a known mass M is hung. The bob is then swung round in a horizontal circle above the head until it is rotating at a constant speed.</p>  <p>It is easy to show theoretically that $Mg = m\omega^2 l$ and hence either M or l can be varied, T measured and the value of g or m determined.</p> <p>A good opportunity for students to plan their data analysis and to consider errors in their data.</p> <p>SAFETY: The body in circular motion presents a risk and adequate space must be available.</p>	Practical	7(f)

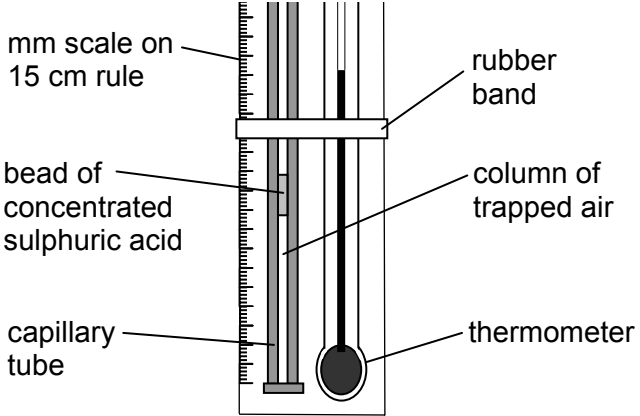
Practical Name	Description / comments	Suitability for practical or demonstration	Link to syllabus learning outcomes
Determination of absolute zero from Charles' law	<p>Students are supplied with a capillary tube, sealed at one end, with a bead of concentrated sulphuric acid in the middle. The column of air trapped between the sealed end and the bead of acid is the fixed mass of gas, and its volume is proportional to its length.</p>  <p>Immerse the capillary tube in a beaker of melting ice and measure the length of the column at different temperatures from 0 °C – 100 °C. By finding the relationship between length and temperature they can extrapolate to find absolute zero, when the length would be zero.</p> <p>This experiment provides a good opportunity to consider the propagation of errors to the final answer.</p>	Practical	11(a), 12(e)

Practical Name	Description / comments	Suitability for practical or demonstration	Link to syllabus learning outcomes
Brownian motion	Using a smoke cell or specialist designed apparatus and a microscope, Brownian motion can be demonstrated. It is also possible to demonstrate this with a very small amount of milk in water, also under a microscope (and sometimes even under a lens).	Practical or demonstration	11(b)
Newton's law of cooling	Detailed in Appendix 2.	Practical	12(a), 13(b)
Calibration of a thermocouple	Students make their own thermocouples from copper and constantan wires, with one junction in melting ice and the other in hot water. Students then calibrate their thermocouples in the range 0 °C – 100 °C using alternative thermometers.	Practical	12(c), 12(d)
Specific heat capacity of oil	Detailed in Appendix 2.	Practical	13(b)
Specific heat capacity of a metal	Similar to the experiment with oil but, instead of a calorimeter containing oil, this experiment uses a solid metal block with a hole in the centre to accommodate the heater and another hole to accommodate the thermometer.	Practical	13(c)
Specific latent heat of vaporisation of water	Detailed in Appendix 2.	Practical	13(c)
Oscillations of a cantilever (1)	Students attach a mass m to the end of a cantilever (e.g. a wooden metre rule) of length l . The cantilever will oscillate vertically with a period T . Students are told that the relationship between T and m is of the form $T = am^n$ and are required to find the value of n (which should be 0.5). A good opportunity for students to plan the analysis of data, requiring a log - log graph.	Practical	14(b)

Practical Name	Description / comments	Suitability for practical or demonstration	Link to syllabus learning outcomes
Oscillations of a cantilever (2)	<p>Students attach a mass m to the end of a cantilever (e.g. a wooden metre rule) of length l. The cantilever will oscillate vertically with a period T. Students are told that the relationship between T and l is of the form $T = al^n$ and are required to find the value of n (which should be 1.5).</p> <p>A good opportunity for students to plan the analysis of data, requiring a log-log graph.</p>	Practical	14(b)
Simple harmonic motion	<p>Students investigate the time period T of a mass m oscillating vertically on a spring of spring constant k, which has the equation $T = 2\pi\sqrt{k/m}$. Varying m and measuring T allows students to determine the value of k.</p> <p>This experiment provides opportunities for students to plan the experiment including selection of apparatus; to plan the analysis of the data; to consider the errors in their data; or any combination of these.</p> <p>If data loggers are available then it is possible to generate plots of displacement against time in order to generate the characteristic graphs. This could form part of a more open-ended investigation or of a demonstration to support a theory lesson.</p> <p>Similar experiments may be done with the simple pendulum if these have not already been done in the AS year.</p>	Practical or demonstration	14(c)

Practical Name	Description / comments	Suitability for practical or demonstration	Link to syllabus learning outcomes
Damping of a pendulum	<p>The motion of a pendulum suspended from two threads can be damped by adding pieces of stiff card to the oscillator to vary the air resistance. Students are asked to investigate the way in which the damping varies with the dimensions of the card. As a measure of damping, students may measure the time taken for the amplitude of the oscillations to fall by half.</p> <p>This activity provides an opportunity for students to plan and carry out an experiment, in which several approaches may be possible. The experiment can be left very open (so that they are not told either to measure the dimensions of the card or how to quantify damping) or some additional guidance can be given.</p> <p>An extension of this would be to look at the behaviour of a mass oscillating on a spring when it is twisted horizontally rather than displaced vertically. Damping could be done by attaching pieces of card of different widths to the mass.</p>	Practical	14(i)

Practical Name	Description / comments	Suitability for practical or demonstration	Link to syllabus learning outcomes
Resonance in an air column	<p>A glass or plastic tube is placed inside a measuring cylinder filled with water. As the tube is raised and lowered, the effective length of the tube changes.</p> <p>A tuning fork is struck and placed just over the end of the tube, which should be as short as possible. The length of the tube is then slowly increased until the loudness of the note becomes a maximum. At this point, a longitudinal standing wave has been set up in the column of air.</p> <p>Students can investigate the relationship between the frequency of the tuning fork (which is normally written on the tuning fork) and the length of the tube. Knowing that the length of tube for the first resonant point is equal to one quarter of the wavelength of the wave, it is possible to measure the speed of sound using the wave equation $v = f\lambda$.</p> <p>The experiment provides opportunities for evaluation and work with experimental errors.</p> <p>Alternatively, this experiment could be done with a signal generator and a loudspeaker instead of a tuning fork.</p> <p>SAFETY: The tuning fork must not touch the glass tube of it may shatter.</p>	Practical	14(j)

Practical Name	Description / comments	Suitability for practical or demonstration	Link to syllabus learning outcomes
Demonstration of electric field patterns	<p>This needs a EHT power supply</p> <p>A circular electrode and a point electrode at the centre of the circle are placed in Petri dish or similar container that is filled with oil. A light sprinkling of grass seed is also placed in the oil (materials other than grass seed can be used but they must be light and able to visibly change orientation). The electrodes are then connected to the EHT supply and the voltage between them slowly increased until the seeds start to orientate in the field pattern.</p> <p>Other electric field patterns can also be demonstrated, e.g. by using two straight electrodes or two point electrodes.</p> <p>The demonstration can be placed on an OHP to ensure that the whole class can see it.</p> <p>SAFETY: This demonstration uses an EHT power supply and is not suitable for students to carry out.</p>	Demonstration	17(g), 17(b)
Discharge of a capacitor	Detailed in Appendix 2.	Practical	18(a), 18(b)

Practical Name	Description / comments	Suitability for practical or demonstration	Link to syllabus learning outcomes
Determining the resistance of a moving-coil voltmeter	<p>When a capacitor of capacitance C discharges through a resistor of resistance R, the voltage V at time t is given by</p> $V = V_0 e^{-t/RC}.$ <p>Students measure the time taken by several known values of capacitance to discharge through the voltmeter to the point where $V = \frac{1}{2} V_0$. This data is then used to find the resistance of the voltmeter.</p> <p>Students may be given three identical capacitors so that they have to use them in series and parallel combinations, working out the combined capacitance.</p> <p>The experiment provides opportunities for students to plan the apparatus they need and how it is to be arranged, and also to plan how to use the data to reach an answer, including rearranging the equation to give</p> $t = RC \ln 2.$	Practical	18(a), 18(e)
Investigation with a Hall probe	Detailed in Appendix 2.	Practical	21(a), 2(a)

Practical Name	Description / comments	Suitability for practical or demonstration	Link to syllabus learning outcomes
Magnetic field patterns	<p>The field patterns for a bar magnet, pairs of magnets, a single current-carrying wire and a solenoid can be observed with iron filings or plotting compasses. If done as a demonstration then this can be placed on an OHP to make it easier to see. Although this will only provide a qualitative display it acts as a good introduction.</p> <p>If clear plastic is placed over the wires and magnets, then it is much easier to collect iron filings at the end.</p>	Practical or demonstration	21(a), 21(b)
Force on a current-carrying wire	Detailed in Appendix 2.	Practical	22(a), 22(b)
Current balance	<p>This equipment is generally available as a specially-designed kit. However, it is possible to make a current balance using stiff wire, with a small piece of wire or paper as a rider.</p> <p>The current in the wire or the position of the magnet is varied, and the wire is re-balanced by moving the rider. If the weight and position of the rider is known, the principle of moments may be used to calculate the force on the wire.</p>	Practical	22(d)

Practical Name	Description / comments	Suitability for practical or demonstration	Link to syllabus learning outcomes
The field around a current-carrying wire and a solenoid	<p>Using a Hall probe, students can investigate the magnetic field created around a single, straight, current-carrying wire and around a solenoid. They can vary the current and investigate the magnetic flux densities at different positions.</p> <p>A 'slinky' spring can be used as the solenoid. This allows students to vary the density of the coils (by stretching the spring), to investigate the effect on the magnetic field when the spring is bent into a circular shape, and to investigate the magnetic field pattern inside the coil.</p>	Practical or demonstration	22(g)
Force between two current-carrying conductors	<p>Two pieces of thin aluminium foil are hung vertically so that they are close to each other but not touching. They need to be taut, so they can be hung from a retort stand with some paperclips or similar attached to the bottom.</p> <p>Current is passed through the two foil 'wires' and their behaviour is observed. The behaviour can be predicted and then observed when the direction of current in the wires is changed.</p>	Demonstration	22(i)

Practical Name	Description / comments	Suitability for practical or demonstration	Link to syllabus learning outcomes
Electromagnetic induction	<p>A single wire connected to a galvanometer (or sensitive ammeter) can be moved through a magnetic field and the maximum current recorded. By changing the direction of motion, orientation of the magnet and connections to the ammeter, it is possible to observe changes in the current. Students should be encouraged to predict the direction of the current by knowing the directions of the magnetic field and of the movement.</p> <p>By creating a coil of wire it is possible to try and gain a set of results for the number of coils against the current, although this will require a constant speed of motion. This experiment allows scope for the consideration of errors.</p>	Practical or demonstration	23(d), 23(f)
Photoelectric effect	It is possible to demonstrate the photoelectric effect with a charged gold leaf electroscope. A clean zinc plate is placed on the charging plate of the electroscope and then charged, causing the leaf to rise. If strong ultra-violet light is shone on the zinc, the electroscope will discharge and the leaf will fall back down.	Demonstration	26(e)

Practical Name	Description / comments	Suitability for practical or demonstration	Link to syllabus learning outcomes
Radioactive dice	<p>The decay behaviour of radioactive materials can be modelled with dice and half-life behaviour observed in graphical analysis.</p> <p>A large number of small cubes (or dice) are marked so that three sides are one colour, two sides are another colour and one side is a third colour. Students select one of the colours and throw all the cubes. They then remove the ones that show the chosen colour and record the number N remaining. They then roll the remaining cubes and continue until none are left. N is then plotted against the number of throws. From this graph, the 'half life' of the cubes can be calculated graphically.</p> <p>Ideally, over 40 dice per set are needed to get a good characteristic graph. The cubes may be made by painting the sides of a square-section wooden rod and then cutting it into cubes.</p>	Practical	27(p)
Behaviour of an LDR	Detailed in Appendix 2.	Practical	28(b), 20(k)
Temperature characteristic of a thermistor	Detailed in Appendix 2.	Practical	28(c), 20(k)
Introduction to the operational amplifier	Activity to introduce students to the connections on an op-amp and to the very large open-loop gain.	Practical	28(h)
The operational amplifier as an inverting amplifier	Detailed in Appendix 2.	Practical	28(h), 28(k), 28(l), 28(m)
The operational amplifier as a non-inverting amplifier	Similar to the experiment on the inverting amplifier.	Practical	28(h), 28(k), 28(m)
Cantilever investigation	Detailed in Appendix 2.	Practical	-

Appendix 2: Examples of A2 practicals

Each of the ten practical activities in this appendix consists of a student worksheet, teaching notes and technical notes. These have been printed on separate pages for ease of photocopying: teachers are welcome to photocopy these pages for use within their own schools.

It is assumed that students will, as a matter of course, be required to write a brief account with a diagram of the experimental arrangement. The worksheets do not make this requirement explicit.

In all cases, the practical activities could be adapted to allow for the fact that different schools have different apparatus available. Most may also be adapted to change the practical skills that are given emphasis. The intention, in this appendix, is to illustrate how an idea for a practical activity may be worked up into student worksheets, teaching notes and technical notes.

One of the characteristics of practical work in the A2 year is that students should be allowed to take more control over deciding how to proceed. From time to time these decisions will prove difficult for some students, and extra guidance will be needed. There are suggestions for extra guidance on the teaching notes with the more open-ended practicals in this appendix.

Newton's Law of Cooling

Student Worksheet

In this activity you will plan and carry out an investigation to see whether Newton's law of cooling applies under different conditions.

Theory

Newton's law of cooling states that the rate of heat loss from an object is approximately proportional to the temperature difference between the object and its surroundings. This can be written as

$$Q \propto \Delta T$$

where Q is the rate at which the temperature of the object is changing and ΔT is the temperature difference between the object and the surroundings.

If a graph of the temperature T of the object is plotted against time t , the gradient of the graph at any point is equal to Q .

Making measurements and observations

In order to collect data, you have been provided with a supply of very hot water, a metal calorimeter can, a stopwatch, a stirrer and thermometer. You have also been provided with an electric fan and stirrer so that you can change the conditions of the experiment. You may ask for any other apparatus that you need.

You must plan how to use your apparatus to collect data that you can analyse. You should write down your plan before you make any measurements.

In your plan, you will need to:

- 1 decide what quantities you need to measure in order to reach a conclusion;
- 2 decide how to use the apparatus to make your measurements;
- 3 decide what variables to keep constant, and how to keep them constant;
- 4 decide what you will change so that you can repeat the experiment under different conditions;
- 5 assess the safety of your experiment and state how you will minimise risks.

After you have written your plan, you should set up your apparatus and make your measurements, recording them in tables of results.

Analysing your data

You should decide how to analyse your data to establish whether the equation

$$Q \propto \Delta T$$

is true under different conditions. You should use graphs in your analysis. State your conclusions clearly.

Evaluation

If you were to repeat the experiment, suggest what changes you would make to the method in order to reduce the experimental errors.

Newton's Law of Cooling

Teaching Notes

Link to theory

12(a) *show an appreciation that thermal energy is transferred from a region of higher temperature to a region of lower temperature.*

13(b) *define and use the concept of specific heat capacity, and identify the main principles of its determination by electrical methods.*

Key learning objectives

- To develop students' planning skills by providing an opportunity to plan, carry out and evaluate an experiment.
- To provide experience of an experiment in which the objective is to determine whether a relationship exists.
- To develop the technique of using the tangent of a curved graph in analysis.
- To reinforce the importance of the treatment of errors through experience of an experiment in which small errors in the raw data may have a large impact on the outcome.

Notes

Newton's law of cooling is not part of the theory syllabus. However, it links well with learning outcome 12(a). In order to reach the equation $Q \propto \Delta T$, students have to appreciate that the rate of heat loss is linked to the rate of change of temperature by the mass and the specific heat capacity of the object. It may be necessary to go through the theory in the introductory section of the lesson, just to ensure that students have understood it.

This experiment is designed to be one of the first in which students are given little guidance on what to do. The Student Worksheet provides minimal guidance. Extra guidance may be given as necessary, as outlined below.

It is important that students write out their plans before starting to collect data, and that they stick to their written plans. In the examination, they will be required to write a plan and then to stop. The experiment will be less effective preparation for the examination if students are allowed to improvise as they proceed.

At the end of the lesson, there should be a discussion about the effects of small errors in the data on the shape of their cooling curves and hence on the outcomes of their experiments. It is hoped that students will realise and include reference to this in their evaluation, although some may need more guidance than others.

Additional guidance for students

Although students may find other ways to conduct their experiment, the following basic steps are expected.

Students who are unsure how to proceed should be asked about their ideas. When it is clear what part of the plan is causing them the greatest difficulty, they can be given some ideas. These may consist of pointing them towards ideas that are already written on the Student Worksheet, or alternatively it may involve showing them how to do a small part of the

experiment. Ideally they should be given just enough of a clue to enable them to work out the rest of the plan for themselves.

- 1 Measure room temperature.
- 2 Fill the calorimeter can with boiling or nearly boiling water.
- 3 Record the volume of water (or the water level) so that, when the experiment is repeated under different conditions, the same volume of water is used.
- 4 Record values for the temperature T and time t as the water cools.
- 5 Repeat the experiment for different conditions, collecting as many sets of data as possible. This may include using a stirrer continuously, using an electric fan blowing cold air over the water or even using some kind of insulation.
- 6 For each set of data, plot a graph of T against t . This graph should be a curve.
- 7 For each set of data, draw tangents at several values of T . Find the gradient Q of each tangent.
- 8 For each set of data, plot a graph of Q against T .
- 9 If the graph is a straight line, then Newton's law of cooling applies. If the graph is curved, the law does not apply.

Expected results

It is expected that the results for this experiment will be variable, and will depend on the ability of the students to draw an accurate curve.

Possible extension work

The analysis of the data from this experiment is particularly suited to ICT methods, either with a spreadsheet or with a graphical analysis package. However, at least one set of data should be analysed without ICT in order to establish that students have the necessary skills.

Newton's Law of Cooling

Technical Notes

Apparatus requirements

- 1 **Electric kettle**, or alternative source of boiling or very hot water.
- 2 **Thermometer**, reading up to 100 °C.
- 3 **Copper calorimeter can** or similar container. A cleaned food can with the label removed would be suitable provided that there are no sharp edges.
- 4 **Heat-proof mat** on which to place the calorimeter can and hot water.
- 5 **Stopwatch** measuring to the nearest second or better.
- 6 **Stirrer**.
- 7 **Electric fan**. Students will need to be able to switch the fan on and off and to direct the flow of air over the calorimeter can.
- 8 **Insulation materials** such as cotton wool or newspaper.

Specific Heat Capacity of Oil

Student Worksheet

In this activity you will plan and carry out an experiment to determine the specific heat capacity of oil.

Theory

The heat energy E produced in a time t by a component in an electric circuit is given by the equation

$$E = VIt$$

where I is the current in the component and V is the potential difference across the component. This equation can be used to calculate the energy produced by an electric heater.

The energy E required to raise the temperature of a liquid is given by the equation

$$E = m_L c_L \Delta T$$

where m_L is the mass of the liquid, c_L is the specific heat capacity of the liquid and ΔT is the change in temperature of the liquid.

If the liquid is being heated inside a metal calorimeter can, then some of the energy is used to raise the temperature of the calorimeter can. The above equation then becomes

$$E = m_L c_L \Delta T + m_C c_C \Delta T$$

where m_C is the mass of the calorimeter can and c_C is the specific heat capacity of the metal from which the calorimeter can is made. The value of c_C is known.

If a metal calorimeter can full of liquid is being heated with an electrical heater, we have the equation

$$VIt = (m_L c_L + m_C c_C) \Delta T.$$

Making measurements and observations

In order to collect data, you have been provided with an electrical heater, a power supply, an ammeter, a voltmeter, some connecting leads, a stopwatch, a metal calorimeter can, a supply of oil, a stirrer, a thermometer and some insulating material. You have access to a balance. You may ask for any other apparatus that you need.

You must plan how to use your apparatus to collect data that you can analyse. You should write down your plan before you make any measurements.

In your plan, you will need to:

- 1 decide what quantities you need to measure in order to carry out the data analysis;
- 2 decide how to use the apparatus to make your measurements;
- 3 assess the safety of your experiment and state how you will minimise risks.

Safety notice: Hot oil is dangerous. You should not heat the oil over 60 °C, and you should take great care not to touch or spill the oil.

After you have written your plan, you should set up your apparatus and make your measurements, recording them in tables of results.

Analysing your data

- 1 Plot a graph of ΔT (y-axis) against t (x-axis). The graph will be slightly curved.
- 2 Draw a tangent to the curve at $\Delta T = 0$. Calculate the gradient of the curve.
- 3 Suggest why the graph is curved. Hence suggest why the gradient to the tangent gives you the correct value for $\Delta T / t$.
- 4 Use your value of $\Delta T / t$ and any other measurements you have made to determine the specific heat capacity c_L of the oil.

Evaluation

What were the major difficulties and sources of error that you encountered in this experiment?

Was there any data that you needed, but which you didn't realise you would need until you reached the data analysis stage?

If you were to repeat the experiment, discuss what changes you would make to the method in order to reduce the experimental errors.

Specific Heat Capacity of Oil

Teaching Notes

Link to theory

13(b) define and use the concept of specific heat capacity, and identify the main principles of its determination by electrical methods.

Key learning objectives

- To develop students' planning skills by providing an opportunity to plan, carry out and evaluate an experiment.
- To give students direct experience of measuring specific heat capacity of a liquid using an electrical method.
- To develop the technique of using the tangent of a curved graph in analysis.

Notes

This experiment is designed to be one of the first in which students are given less guidance on what to do. The Student Worksheet provides minimal guidance on the experimental arrangement, but provides a list of apparatus and some guidance on the analysis of the data. Extra guidance may be given as necessary, as outlined below.

It is important that students write out their plans before starting to collect data, and that they stick to their written plans. In the examination, they will be required to write a plan and then to stop. The experiment will be less effective preparation for the examination if students are allowed to improvise as they proceed.

If the insulation is efficient, the graph may not be noticeably curved. In this case, the tangent will be the best-fit straight line through the data.

Additional guidance for students

Although students may find other ways to conduct their experiment, the following basic steps are expected.

Students who are unsure how to proceed should be asked about their ideas. When it is clear what part of the plan is causing them the greatest difficulty, they can be given some ideas. These may consist of pointing them towards ideas that are already written on the Student Worksheet, or alternatively it may involve showing them how to do a small part of the experiment. Ideally they should be given just enough of a clue to enable them to work out the rest of the plan for themselves.

- 1 Measure room temperature.
- 2 Measure the mass of the empty calorimeter can.
- 3 Fill the calorimeter can with oil.
- 4 Measure the mass of the calorimeter can with the oil inside it.
- 5 Insulate the can and place it on the heat-proof mat. Place the thermometer and the stirrer in the oil.
- 6 Set up the circuit for the electric heater, ensuring that the supply voltage is correct. The ammeter and the voltmeter should be connected so that V and I can be measured.

- 7 Record the values of V and I when the heater is switched on. Switch off.
- 8 Place the heater into the oil, ensuring that it does not touch the metal sides of the calorimeter.
- 9 Record the temperature of the oil.
- 10 Switch on and, at the same time, start the stopwatch. Record the temperature of the oil at regular intervals, stirring the liquid to ensure that it is all at the same temperature. Check that the values of V and I do not change. When the temperature of the oil approaches 60°C or when 10 minutes have elapsed, switch off.
- 11 Allow the oil to cool without touching the apparatus.
- 12 For each value of temperature, calculate ΔT (the temperature change of the oil since the beginning of the experiment).
- 13 Plot the graph as instructed on the Student Worksheet and hence find the value of $\Delta T / t$.
- 14 Use the equation to calculate c_L .

Expected results

The specific heat capacity of oil can vary considerably from $800 \text{ J kg}^{-1} \text{ K}^{-1}$ to $2000 \text{ J kg}^{-1} \text{ K}^{-1}$, depending on the type of oil.

Possible extension work

Similar experiments can be done with other suitable liquids in order to give students a feel for typical values of specific heat capacity. Suitable liquids are those that are not flammable or explosive, that have a high boiling point, that are non-toxic and that do not produce toxic vapour.

If the graph is substantially curved, further investigations can be done on the rate of heat loss from the calorimeter and its relationship to the temperature of the oil, either by drawing tangents to the curve that the students obtained or by plotting cooling curves.

Specific Heat Capacity of Oil

Technical Notes

Apparatus requirements

- 1 Copper calorimeter can** or similar container. A cleaned food can with the label removed would be suitable provided that there are no sharp edges. The calorimeter can should have a wooden or cork lid with holes for the thermometer and the stirrer.
- 2 Insulation material**, such as cotton wool or crumpled newspaper, with tape or elastic bands to secure it.
- 3 Heat-proof mat** on which to place the calorimeter can and hot water.
- 4 Cooking oil**, sufficient to fill the calorimeter can. Any type of cooking oil will work, e.g. olive oil, sunflower oil.
- 5 Stirrer.**
- 6 Thermometer**, reading up to 100 °C.
- 7 Access to a balance.** Several students may share the same balance. An electronic top-pan balance is most suitable.
- 8 Stopwatch** measuring to the nearest second or better.
- 9 Electric immersion heater.** Commercially-produced immersion heaters are usually 12V, 100W although similar 60W ones are still suitable. If a commercially-produced immersion heater is not available, then a heater may be constructed from a length of resistance wire (e.g. 1.00 m of 28 swg constantan wire) wound around a pencil to form a coil.
- 10 Power supply**, variable up to 12 V d.c., low resistance.
- 11 Voltmeter** capable of measuring the operating voltage of the immersion heater. A digital multimeter would be suitable.
- 12 Ammeter** capable of measuring the current in the immersion heater. A digital multimeter would be suitable.
- 13 Five connecting leads.**
- 14 Card** stating the specific heat capacity of the metal from which the calorimeter can is made and the operating voltage of the immersion heater.

Specific Latent Heat of Vaporisation of Water

Student Worksheet

In this activity you will plan and carry out an experiment to determine the specific latent heat of vaporisation of water, including an error estimate in your answer.

Theory

The heat energy E produced in a time t by a component in an electric circuit is given by the equation

$$E = VIt$$

where I is the current in the component and V is the potential difference across the component. This equation can be used to calculate the energy produced by an electric heater.

The energy E required to change a mass m of liquid into gas without any change in temperature is given by the equation

$$E = mL$$

where L is the specific latent heat of vaporisation of the liquid.

If an electrical heater is used to boil water, and if heat losses can be ignored, then it follows that

$$VIt = mL$$

where t is a time period throughout which the water was at its boiling temperature and m is the mass of water that became steam during this time.

Making measurements and observations

You have been provided with an electrical heater, a power supply, an ammeter, a voltmeter, some connecting leads, a stopwatch, a metal calorimeter can with a lid, a supply of water, a stirrer, a thermometer, and a cloth.

You have access to a balance, but you may **not** use the balance continuously.

You may ask for any other apparatus that you need.

Plan how to make measurements of V , I , t and m . You must write down your plan before you make any measurements.

Safety notice: during the experiment, the metal calorimeter can and the water will become very hot. Care must be taken to avoid burns and scalds. The hot metal must not be touched and the calorimeter can should only be moved with the lid on.

After you have written your plan, set up the apparatus and make your measurements. Include an error estimate with each measurement.

Analysing your data

Substitute your measured values of V , I , t and m into the equation

$$VIt = mL$$

and hence determine a value for the specific latent heat of vaporisation of water L .

Using the error estimates in your measurements, determine the error estimate in your value for L .

Evaluation

Write down the major sources of difficulty and error in your experiment.

If you were able to repeat the experiment, what would you change in order to improve its accuracy?

If you were able to use the balance continuously, how would you improve the experimental method?

Specific Latent Heat of Vaporisation of Water

Teaching Notes

Link to theory

13(c) *define and use the concept of specific latent heat, and identify the main principles of its determination by electrical methods.*

Key learning objectives

- To reinforce AS level skills of error estimation and propagation.
- To introduce the idea that an experimentally-determined value needs an error estimate in order to be meaningful.
- To develop students' planning skills by providing an opportunity to plan, carry out and evaluate an experiment.
- To give students direct experience of measuring specific latent heat using an electrical method.

Notes

The Student Worksheet provides some guidance on the experimental arrangement, but provides a list of apparatus and quite full guidance on the analysis of the data. Extra guidance may be given as necessary, as outlined below.

It is important that students write out their plans before starting to collect data, and that they stick to their written plans. In the examination, they will be required to write a plan and then to stop. The experiment will be less effective preparation for the examination if students are allowed to improvise as they proceed.

If this activity is done as a whole-class practical session, then it is a good idea to end the lesson with a comparison of the different groups' results and a discussion of their error margins. Many groups will have underestimated the inaccuracies in this experiment and will have results that do not tally with the accepted value, which provides a good start to a discussion about the sources of error and the importance of calculating error estimates.

The students' written evaluations may be informed by the class discussion and completed as homework.

Additional guidance for students

Although students may find other ways to conduct their experiment, the following basic steps are expected.

Students who are unsure how to proceed should be asked about their ideas. When it is clear what part of the plan is causing them the greatest difficulty, they can be given some ideas. These may consist of pointing them towards ideas that are already written on the Student Worksheet, or alternatively it may involve showing them how to do a small part of the experiment. Ideally they should be given just enough of a clue to enable them to work out the rest of the plan for themselves.

- 1 Fasten the insulation around the calorimeter can.
- 2 Fill the calorimeter can with water to about three-quarters full.

- 3 Measure the mass m_1 of the calorimeter can with the water inside it (including the insulation, lid, and heater).
- 4 Place the can on the heat-proof mat.
- 5 Set up the circuit for the electric heater, ensuring that the supply voltage is correct. The ammeter and the voltmeter should be connected so that V and I can be measured. Ensure that the heater is completely immersed in the water and is not touching the metal sides of the calorimeter.
- 6 Switch on and bring the water to its boiling temperature. As soon as it begins to boil, start the stopwatch.
- 7 Record the values of V and I .
- 8 After about ten minutes, before the water level drops below the immersion heater, switch off and stop the stopwatch. Place the lid on the can to minimise any further loss of steam.
- 9 Disconnect the heater from the circuit and measure the mass m_2 of the calorimeter can with the remaining water in it, including the lid, insulation and heater. (The heater will be wet and should therefore not be removed, which is why it was also included in m_1 . The same principle should apply to the thermometer and the stirrer if they have been used, although they are not necessary.)
- 10 Make the approximation that $m = m_1 - m_2$. (In fact m will be less than this because some of the water evaporates before and after the period t .)
- 11 Allow the apparatus to cool.

Expected results

The specific latent heat of vaporisation of water is approximately 2300 J kg^{-1} .

Many students will obtain results that are inaccurate because the value of m is not accurately determined and because there will be some heat losses through the insulation. Their error estimates should take this into account.

Possible extension work

If there is sufficient equipment, students can repeat the experiment on a top-pan balance so that they can obtain a more accurate value for m .

Specific Latent Heat Capacity of Vaporisation of Water

Technical Notes

Apparatus requirements

- 1 **Copper calorimeter can** or similar container. A cleaned food can with the label removed would be suitable provided that there are no sharp edges. The calorimeter can should have a wooden or cork lid with holes for the thermometer and the stirrer.
- 2 **Insulation material**, such as cotton wool or crumpled newspaper, with tape or elastic bands to secure it.
- 3 **Heat-proof mat** on which to place the calorimeter can and hot water.
- 4 **Supply of cold water**, sufficient to fill the calorimeter can.
- 5 **Stirrer**.
- 6 **Thermometer**, reading up to 100 °C.
- 7 **Access to a balance**. Several students may share the same balance. An electronic top-pan balance is most suitable.
- 8 **Stopwatch** measuring to the nearest second or better.
- 9 **Electric immersion heater**, suitable for immersion in boiling water. Commercially-produced immersion heaters are usually 12V, 100W although similar 60W ones are still suitable. If a commercially-produced immersion heater is not available, then a heater may be constructed from a length of resistance wire (e.g. 1.00 m of 28 swg constantan wire) wound around a pencil to form a coil.
- 10 **Power supply**, variable up to 12 V d.c., low resistance.
- 11 **Voltmeter** capable of measuring the operating voltage of the immersion heater. A digital multimeter would be suitable.
- 12 **Ammeter** capable of measuring the current in the immersion heater. A digital multimeter would be suitable.
- 13 **Five connecting leads**.
- 14 **Card** stating the operating voltage of the immersion heater.

Discharge of a Capacitor Student Worksheet

In this activity you will investigate the discharge of a capacitor through a resistor in order to determine the capacitance of the capacitor.

Theory

When an uncharged capacitor is connected to a power supply, charge will flow onto the plates of the capacitor, and the capacitor will become charged. If the resistance in the circuit is small, the capacitor will become charged very quickly. The capacitor will remain charged when the power supply is disconnected.

When the charged capacitor is connected to a resistor, it discharges through the resistor. The discharge may be quite slow, depending on the resistance of the resistor and the capacitance of the capacitor.

The diagram below shows a circuit for charging a capacitor and then discharging it through a resistor. When the flying lead is connected to A, the capacitor quickly becomes charged. When the flying lead is connected to B, the capacitor discharges through the resistor.

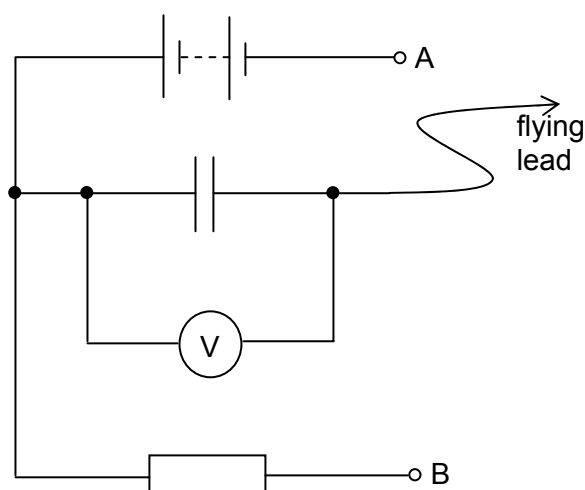

When a capacitor of capacitance C is discharged through a resistor of resistance R , the potential difference V_t across the capacitor at time t is given by the equation.

$$V_t = V_0 e^{-\frac{t}{RC}}$$

where V_0 is the potential difference across the capacitor at time $t = 0$.

Making measurements and observations

Using the circuit components provided, connect the circuit shown in the diagram.

Make measurements of V_t and t as the capacitor discharges through the resistor.

Analysing your data

Rearrange the equation

$$V_t = V_0 e^{-\frac{t}{RC}}$$

so that it becomes a linear relationship.

Use this relationship to plot a straight-line graph from your data.

From this graph, determine the capacitance C of the capacitor.

Discharge of a Capacitor

Teaching Notes

Link to theory

- 18(a) show an understanding of the function of capacitors in simple circuits.
 18(b) define capacitance and the farad.

Key learning objectives

- To give students the opportunity to investigate the behaviour of a capacitor.
- To give students experience in an experimental context of rearranging an exponential equation to give a linear equation, and to see how this is useful in data analysis.

Notes

The Student Worksheet provides guidance on the experimental arrangement and on the data to be collected. Students are more likely to require additional guidance with the analysis of their data.

Additional guidance for students

- 1 Rearranging of the equation:

$$V_t = V_0 e^{\frac{-t}{RC}}$$

$$\frac{V_t}{V_0} = e^{\frac{-t}{RC}}$$

$$\ln \frac{V_t}{V_0} = \frac{-t}{RC}$$

$$\ln V_t = \frac{-1}{RC} t + \ln V_0$$

So the relationship between $\ln V_t$ and $\ln V_0$ is linear.

- 2 Plot a graph of $\ln V_t$ (y-axis) against t (x-axis).
- 3 The gradient of the graph is $\frac{-1}{RC}$. The value of R is known. Therefore the value of C may be calculated.

Expected results

The experiment should give a reliable value for C .

Possible extension work

Candidates can repeat the experiment with different values of C and R to verify the relationship. They can design experiments to investigate charging. They can observe the variation of current as the capacitor is discharged and hence investigate the charge and energy stored on the capacitor.

Discharge of a Capacitor

Technical Notes

Apparatus requirements

- 1 **Power supply**, low voltage d.c. A battery would be suitable.
- 2 **Capacitor**.
- 3 **Resistor**, with its resistance clearly labelled. The value of RC should be about 50 s to 100 s, e.g. a 500 μF capacitor can be used with a 100 $\text{k}\Omega$ resistor, or a 2200 μF capacitor can be used with a 33 $\text{k}\Omega$ resistor.
- 4 **Voltmeter**, capable of measuring the supply voltage. A digital multimeter would be suitable.
- 5 **Four crocodile clips**.
- 6 **Five connecting leads**.
- 7 **Stopwatch** measuring to the nearest second or better.

Investigation with a Hall Probe

Student Worksheet

In this activity you will investigate how the orientation of a Hall probe affects its measurement of magnetic flux density.

Theory

A Hall probe is an electrical device that is designed to measure the strength of a magnetic field.

A Hall probe is made from a slice of conducting material, as shown in the diagram. A current is passed through the Hall probe from side P to side Q. The current is carried by charged particles flowing across the Hall probe. If the Hall probe is in a magnetic field, the charged particles are deflected from their course, and this produces a potential difference between sides R and S. This potential difference between sides R and S is called the Hall voltage.

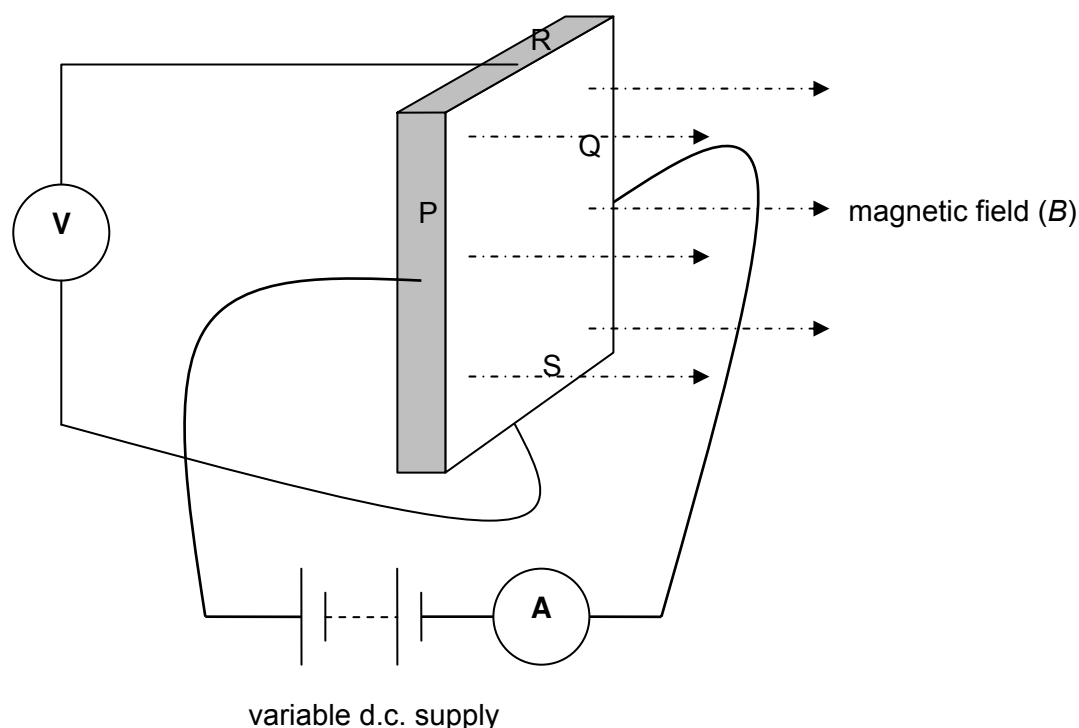

The Hall voltage is proportional to the magnetic flux density. If the Hall probe has been calibrated against a known magnetic field, then it is possible to get a direct reading of the flux density B rather than a reading of the Hall voltage.

The Hall voltage also depends on the orientation of the Hall probe. From the diagram, the charged particles are deflected most if the PQ direction is perpendicular to the magnetic field. The particles will not be deflected at all if the PQ direction is parallel to the magnetic field. A calibrated Hall probe will only give the correct reading if the PQ direction is perpendicular to the magnetic field.

Theory suggests that the reading r on a calibrated Hall probe is related to the angle θ between the PQ direction and the magnetic field by the equation

$$r = B \sin\theta$$

where B is the magnetic flux density.

Making measurements and observations

Using the apparatus provided, fix the Hall probe in the magnetic field and then rotate the probe.

Record values of r and θ . Include error estimates in your table of results.

With the aid of a diagram, describe:

- 1 how you arranged the apparatus;
- 2 how you ensured that the position of the Hall probe did not change when the value of θ was changed;
- 3 how you measured the angle θ .

Analysing your data

- 1 Plot a graph of r (y -axis) against $\sin\theta$ (x -axis). Include error bars on your graph.
- 2 Within the limits of experimental accuracy, state whether your data supports the equation

$$r = B \sin\theta.$$

- 3 Use your graph to determine a value for the magnetic flux density B .

Evaluation

State the major sources of error and difficulty in this experiment. Suggest what improvements could be made to the experiment in order to make it more accurate.

Investigation with a Hall Probe

Teaching Notes

Link to theory

21(a) show an understanding that a magnetic field is an example of a field of force produced either by current-carrying conductors or by permanent magnets.

2(a)(9) use a calibrated Hall probe.

Key learning objectives

- To gain familiarity with the use of a calibrated Hall probe.
- To extend experience of planning the collection of data.
- To give practice in the calculation of error estimates in derived quantities.
- To introduce the use of error bars on graphs.

Notes

This practical activity is designed to introduce students not only to the Hall probe but also to the display of error bars on graphs. Students are assumed to have learned how to calculate errors in derived quantities such as $\sin\theta$ and to have some prior experience of planning.

The idea of error bars on graphs should be shown to students in the introductory part of this lesson. This should include a discussion of the use of error bars in locating best-fit lines and in deciding whether data is linear or not. The practical activity then provides the necessary reinforcement.

Students should also be shown how to use the Hall probe, including connections if these are required. If the Hall probe is not calibrated, the reading will be a voltage, and the constant of proportionality between r and $\sin\theta$ will not be equal to the magnetic flux density.

In this practical activity, a written plan is not required before data collection begins. This is because some of the problems are difficult to visualise or to describe in advance, and some experimentation with the apparatus may be needed before a solution is found.

The Student Worksheet provides very little guidance on the experimental arrangement. Extra guidance may be given as necessary, as outlined below.

At the end of the activity, it is a good idea to hold a brief discussion about the usefulness (or otherwise) of error bars on the graph, and to discuss the problems encountered in collecting data.

The students' written evaluations may be informed by the class discussion and completed as homework.

Additional guidance for students

Although students may find other ways to conduct their experiment, the following basic steps are expected.

Students who are unsure how to proceed should be asked about their ideas. When it is clear what part of the plan is causing them the greatest difficulty, they can be given some ideas. Ideally they should be given just enough of a clue to enable them to work out the rest of the plan for themselves.

- 1 Place the horseshoe magnet securely on the bench.

- 2 The Hall probe should be clamped in position so that it remains in the same place.
- 3 A decision must be made about whether to rotate the Hall probe, the whole retort stand assembly with the Hall probe, or the magnet. The easiest arrangement is usually to have the Hall probe clamped in a vertical position between the poles of the magnet; to have the magnet arranged so that the magnetic field is horizontal; and to rotate the magnet on the bench.
- 4 The orientation of the Hall probe and the magnet where $\theta = 0$ must be found and marked, so that there is no zero error in subsequent values of θ .
- 5 A way must be found to measure subsequent values of θ . This is easiest if the magnet is being rotated on the desk: the magnet can be placed on a sheet of paper affixed to the bench with Sellotape and the various positions of the magnet traced out. The values of θ can then be measured from the paper. Measuring θ is considerably more difficult (but not impossible) if the Hall probe is being rotated.

Expected results

The relationship should be correct within the margins of error. The most common mistake is likely to be a zero error in values of θ , which may produce considerable distortion of the graph.

Possible extension work

The experiment is made considerably easier by the use of a turntable. A simple turntable can be constructed from a pair of circular dinner plates and some small ball bearings. This can be demonstrated.

The best form of further work is to require the students to use the Hall probe as a measuring device in other practical activities. This activity should not be the only time that the Hall probe is used.

Investigation with a Hall Probe

Technical Notes

Apparatus requirements

- 1 **Calibrated Hall probe**, together with the necessary power supply, meter and connecting leads, as specified in the manufacturer's instructions.
- 2 **Large horseshoe magnet**. This needs to be large enough for the Hall probe to be rotated between the poles.
- 3 **Protractor**.
- 4 **Retort stand, boss and clamp**.
- 5 **Sheet of blank A4 paper**.
- 6 **Sellotape**.

Force on a Current-Carrying Wire

Student Worksheet

In this activity you will plan and carry out an experiment to investigate the force on a current-carrying wire.

Theory

When a wire carrying a current I is in a magnetic field of flux density B , the wire will experience a force. The size of the force F is given by the equation

$$F = BIl \sin \theta$$

where l is the length of wire in the field and θ is the angle between the magnetic field and the wire. The direction of the force is given by Fleming's left-hand rule.

According to Newton's third law, an equal and opposite force acts upon the magnet.

It is possible to measure the force on the magnet by placing the magnet on the scales of a balance and positioning the current-carrying wire between its poles.

Making measurements and observations

In this activity, you are to verify that the force F on the magnet is directly proportional to the current I in the wire.

Begin by writing a plan of the whole experiment. You should write this plan before you begin to work with the apparatus. In your plan, you should

- 1 describe, with the help of a diagram, how the apparatus will be arranged;
- 2 discuss the control of variables;
- 3 explain how you will vary and measure the independent variable;
- 4 explain how you will measure the dependent variable;
- 5 describe how the data you collect will be analysed;
- 6 discuss any safety considerations.

After you have written your plan, you should use the apparatus to collect data, following your plan.

Analysing your data

When you have collected sufficient data, you should analyse it, following your plan. State your conclusions clearly.

Evaluation

Describe the difficulties and sources of error that you encountered when following your plan. Describe what you would do differently if you were to repeat the investigation, and state how the experimental errors could be reduced.

Force on a Current-Carrying Wire

Teaching Notes

Link to theory

22(a) *show an appreciation that a force might act on a current-carrying conductor placed in a magnetic field.*

22(b) *recall and solve problems using the equation $F = BIl \sin\theta$, with directions as interpreted by Fleming's left-hand rule.*

Key learning objectives

- To reinforce the theoretical understanding of forces on current-carrying conductors.
- To provide an opportunity to plan, carry out and evaluate a whole experiment.

Notes

The experiment is designed to strengthen students' planning skills. They will be required to plan the whole experiment from start to finish, including the method used to analyse the data. If more than one group is working on this practical, it may be possible to ask them to exchange plans and to carry out each others' plans.

Students should include a treatment of errors when they carry out the experiment. This should include all the techniques taught so far, including the use of error bars on the graph.

Additional guidance on how to proceed should only be given if absolutely necessary, and should be kept to a minimum. Students should work out as much of the plan as they can, by themselves.

Additional guidance for students

Although students may find other ways to conduct the experiment, the arrangement shown below and the following basic steps are expected.

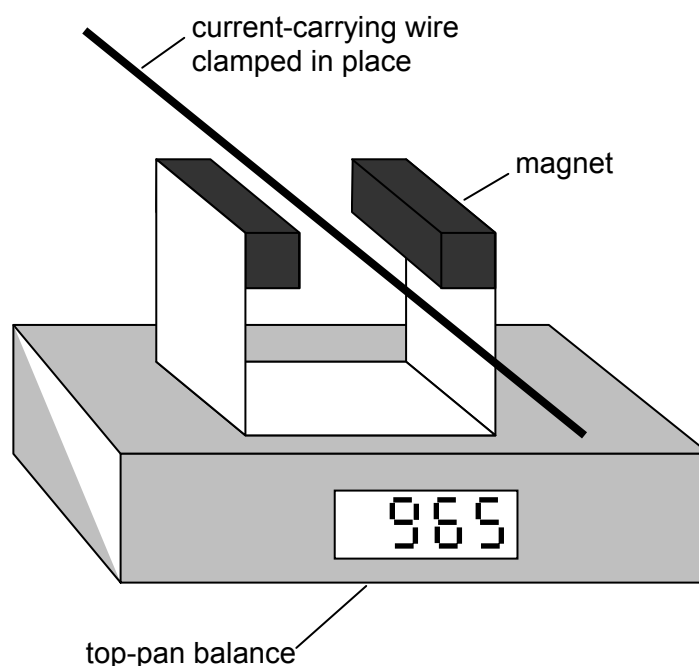

- 1 Place the magnet on the pan of the balance. Record the mass.
- 2 Clamp the stiff piece of copper wire so that it passes between the poles of the magnet and is perpendicular to the magnetic field. The wire should be clamped firmly at both ends so that it cannot move.
- 3 Connect the stiff piece of copper wire in series with the power supply and the ammeter.
- 4 Vary the current in the wire and record the ammeter reading and the balance reading each time.
- 5 The force F is equal to g multiplied by the difference between the balance readings with and without the current.
- 6 Plot a graph of F (y -axis) against I (x -axis).
- 7 If F is proportional to I , the graph should be a straight line that passes through the origin.

Expected results

The data should confirm the relationship. The most common error is usually a failure to multiply the mass readings on the balance by g to obtain the force.

Possible extension work

Further work can be done to investigate the relationship between F and I , and hence to find the value of B . The value of B can be checked with a Hall probe.

The force between a flat ceramic magnet and a current-carrying coil may be investigated in a similar way.

Force on a Current-Carrying Wire

Technical Notes

Apparatus requirements

- 1** **Top-pan balance**, reading to 0.1 g or better.
- 2** **U-shaped or large horseshoe magnet.**
- 3** **Piece of copper wire**, length 30 cm – 50 cm, thick enough to be stiff.
- 4** **Two retort stands, bosses and clamps.**
- 5** **Two crocodile clips.**
- 6** **Power supply**, continuously variable d.c. output, low resistance.
- 7** **Ammeter**, capable of reading 5 A to a precision of at least 0.1 A. A digital multimeter is suitable.
- 8** **Three connecting leads.**

Behaviour of a Light-Dependent Resistor

Student Worksheet

In this activity you will investigate the relationship between the resistance of a light-dependent resistor (LDR) and its distance from a light source.

Theory

An LDR is an electrical device whose resistance changes with the intensity of the light incident on it. When the intensity of light increases, its resistance decreases.

The intensity of light incident on the LDR depends on the distance between the LDR and the light source. When the distance increases, the intensity decreases.

It is suggested that the resistance R of the LDR and the distance d between the LDR and the light source are related by the equation

$$R = ad^b$$

where a and b are constants.

Making measurements and observations

You have been provided with an LDR that is fixed inside the end of a long cardboard tube. You have also been provided with a lamp attached to the end of a metre rule. The metre rule may be pushed into the tube by different distances, so that the distance d between the lamp and the LDR can be varied.

Write a plan for collecting measurements of R and d . In your plan, you should

- 1 describe, with the help of a diagram, how the apparatus will be arranged;
- 2 explain how d and R will be measured;
- 3 discuss the control of variables;
- 4 discuss any safety considerations.

After you have written your plan, you should use the apparatus to collect data, following your plan. Include error estimates in your table of results.

Analysing your data

Rearrange the equation

$$R = ad^b$$

to give the equation of a straight line.

Using the rearranged equation, plot a straight line graph of your data.

From your straight line, find the values of the constants a and b . Include error estimates with your answers.

Evaluation

Describe the difficulties and sources of error that you encountered when following your plan. Describe what you would do differently if you were to repeat the investigation, and state how the experimental errors could be reduced.

Behaviour of a Light-Dependent Resistor

Teaching Notes

Link to theory

28(b) *show an understanding of the change in resistance with light intensity of a light-dependent resistor (LDR).*

20(k) *explain the use of thermistors and light-dependent resistors in potential dividers to provide a potential difference which is dependent on temperature and illumination respectively.*

Key learning objectives

- To familiarize students with the behaviour of a light-dependent resistor.
- To provide an opportunity to plan, carry out and evaluate an experiment.
- To provide experience of the use of log-log graphs where relationships are of the form $y = ax^n$.
- To provide practice in the treatment and propagation of errors.

Notes

It is assumed that, by the time the students do this practical, they will already have been taught how to treat errors as described in the syllabus. This practical practices all of these skills.

The Student Worksheet provides some guidance on the experimental arrangement, and very little guidance on the analysis of the data. Extra guidance should be given as necessary, as outlined below.

It is important that students write out their plans before starting to collect data, and that they stick to their written plans. In the examination, they will be required to write a plan and then to stop. The experiment will be less effective preparation for the examination if students are allowed to improvise as they proceed.

Additional guidance for students

Although students may find other ways to conduct the experiment, the following basic steps are expected.

- 1 The LDR should be connected to the power supply, the ammeter and the voltmeter as shown overleaf. The voltage output of the power supply should be kept constant and the value of R calculated using Ohm's law.
- 2 The lamp should be connected to the battery.
- 3 When the lamp is inside the tube, the cloth should be draped over the open end of the tube to prevent stray light from entering.
- 4 The length L of the tube should be measured. The length l of metre rule inside the tube should be measured. The distance d can be calculated from $d = L - l$.

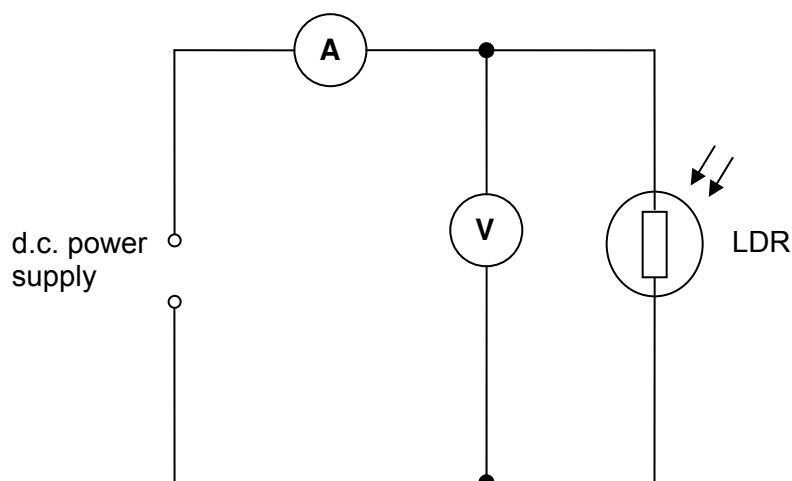

- 5 Rearranging the equation.

$$R = ad^b$$

$$\lg R = \lg(ad^b)$$

$$\lg R = \lg a + b \lg d$$

so there is a linear relationship between $\lg R$ and $\lg d$.

- 6 The graph should be $\lg R$ (y -axis) against $\lg d$ (x -axis).
 7 $\lg a$ is the y -intercept of the graph and b is the gradient of the graph.

Expected results

The log-log graph should produce a good straight line. The value of a will vary significantly depending on the lamp used. The value of b should in principle be 2, although this depends on the type of LDR used and on the amount of scattering of light inside the tube.

Possible extension work

If a light meter is available, the LDR could be used in a potential divider and a calibration curve produced for the output of the potential divider in different light intensities.

Behaviour of a Light-Dependent Resistor

Technical Notes

Apparatus requirements

- 1 **Torch lamp attached to a metre rule**, e.g. a 3 V 0.3 A lamp. The lamp should be fixed with its filament at the zero mark of the rule. Connecting leads 120 cm long should be attached to the two terminals of the lamp.
- 2 **LDR in a cardboard tube**. The tube should be 50 cm to 100 cm long and the internal diameter should be large enough to allow the lamp on the metre rule to fit into the tube. The cardboard should be thick enough to be light proof and should have a matt surface if possible. The tube should be closed at one end, and the LDR should be set into the cap at the closed end. The light-sensitive surface should be facing into the tube and the connecting wires should pass through the cap so that connections can be made from the outside. The closed end of the tube should be light proof.
- 2 **Battery**, voltage suitable for the lamp, with terminals suitable for connecting to the leads from the lamp.
- 4 **Power supply**, variable low voltage d.c.
- 5 **Voltmeter**, suitable for measuring the output from the power supply. A digital multimeter would be suitable.
- 6 **Ammeter**. The range will depend on the resistance of the LDR in bright conditions. A digital multimeter would be suitable.
- 7 **Five connecting leads**.
- 8 **Two crocodile clips**.
- 9 **Small cloth**, thick enough and dark enough to be reasonably light proof.

The Temperature Characteristic of a Thermistor

Student Worksheet

In this activity you will investigate the behaviour of a thermistor.

Theory

A thermistor is an electrical component whose resistance changes with temperature.

It is suggested that the resistance R_T of a particular thermistor at an absolute temperature T is given by the equation

$$R_T = R_0 e^{\frac{b}{T}}$$

where R_0 and b are constants.

In this activity you will find the values of R_0 and b for the thermistor provided.

Making measurements and observations

You have been provided with a thermistor which will not be harmed by immersion in water. You also have a Bunsen burner and access to some iced water. You should decide what other apparatus you need and ask for it.

Plan an experiment to collect values of R_T and T over a temperature range from 0 °C to 100 °C. Do not set up the apparatus until you have written your plan. In your plan you should

- 1 list the apparatus requirements of your experiment;
- 2 describe, with the help of a diagram, how the apparatus will be arranged;
- 3 describe how you will vary and measure the independent variable;
- 4 describe how you will measure the dependent variable;
- 5 discuss the control of other variables;
- 6 describe any precautions you plan to take to minimise experimental errors;
- 7 discuss any safety considerations.

After you have written your plan, set up the apparatus and collect data, following your plan. Include error estimates in your table of results.

Analysing your data

Rearrange the equation

$$R_T = R_0 e^{\frac{b}{T}}$$

to give the equation of a straight line.

Use this equation to plot a straight-line graph of your data.

Comment on whether the equation is applicable to your thermistor.

Use your graph to determine the values of R_0 and b . Include error estimates in your answer.

Evaluation

Describe the difficulties and sources of error that you encountered when following your plan. Describe what you would do differently if you were to repeat the experiment, and suggest how experimental errors could be minimised.

The Temperature Characteristic of a Thermistor

Teaching Notes

Link to theory

- 28(c) *sketch the temperature characteristic of a negative temperature coefficient thermistor.*
20(k) *explain the use of thermistors and light-dependent resistors in potential dividers to provide a potential difference which is dependent on temperature and illumination respectively.*

Key learning objectives

- To familiarize students with the behaviour of a thermistor.
- To provide an opportunity to plan, carry out and evaluate an experiment without the benefit of a list of apparatus.
- To provide experience of the use of log-linear graphs for exponential relationships.
- To provide practice in the treatment and propagation of errors.

Notes

It is assumed that, by the time the students do this practical, they will already have been taught how to treat errors as described in the syllabus. This practical practices all of these skills.

The Student Worksheet provides very little guidance on the experimental arrangement and on the analysis of the data. Extra guidance should be given as necessary, as outlined below.

It is important that students write out their plans before starting to collect data, and that they stick to their written plans. In the examination, they will be required to write a plan and then to stop. The experiment will be less effective preparation for the examination if students are allowed to improvise as they proceed.

Additional guidance for students

Although students may find other ways to conduct the experiment, the following basic steps are expected.

- 1 The thermistor should be connected to a power supply, an ammeter and a voltmeter as shown overleaf. The voltage output of the power supply should be kept constant and the value of R_T calculated using Ohm's law. (Alternatively some students may decide to use a digital multimeter as an ohmmeter.)
- 2 The thermistor should initially be immersed in a beaker of iced water, and the temperature should be varied by heating the water with a Bunsen burner. Care should be taken not to allow the thermistor to touch the sides of the beaker. The water should be stirred and the temperature should be measured with the thermometer.

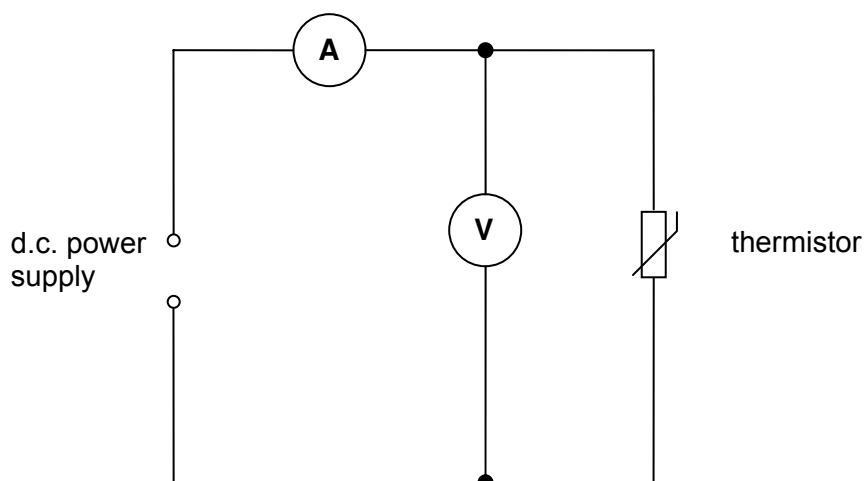

3 Rearranging the equation.

$$R_T = R_0 e^{\frac{b}{T}}$$

$$\lg R_T = \lg (R_0 e^{\frac{b}{T}})$$

$$\lg R_T = b \frac{1}{T} + \lg R_0$$

so there is a linear relationship between $\lg R_T$ and $\frac{1}{T}$.

4 The graph should be $\lg R_T$ (y -axis) against $\frac{1}{T}$ (x -axis).

5 $\lg R_0$ is the y -intercept of the graph and b is the gradient of the graph.

Expected results

The equation is an approximation to the behaviour of a thermistor and will not produce a perfect straight line.

The students should have calculated error estimates in their answers.

Possible extension work

The graph that has been drawn can be considered as a calibration line. The thermistor can be used as a thermometer to measure the temperature of, for example, a cup of tea, and the result compared with that from a liquid-in-glass thermometer.

Students could be asked to write a user guide on the use of the thermistor as a thermometer.

The Temperature Characteristic of a Thermistor

Technical Notes

Note

In this practical, only a few items are initially supplied for the students. They are required to plan their experiment, including producing a list of the apparatus they will need, and to request the apparatus. It is likely that they will request some items that are not listed below.

Apparatus requirements: to be supplied initially

- 1 **Thermistor**, with a negative temperature coefficient. Temperatures of 0 °C to 100 °C should be within the operating range of the thermistor.
- 2 **Access to a supply of iced water.**
- 3 **Bunsen burner.**

Apparatus requirements: items that students are likely to request

- 4 **Heat proof mat.**
- 5 **Tripod and gauze.**
- 6 **Pyrex beaker**, 500 cm³.
- 7 **Thermometer**, -10 °C to 110 °C.
- 8 **Power supply**, low voltage d.c. A battery would be suitable, but the terminals should be suitable for connecting to the leads.
- 9 **Voltmeter**, with a range appropriate for measuring the power supply voltage. A digital multimeter would be suitable.
- 10 **Ammeter**, the appropriate range will depend on the supply voltage used and on the thermistor. A digital multimeter would be preferable to a single-range meter.
- 11 **Five connecting leads.**
- 12 **Two crocodile clips.**

The Operational Amplifier as an Inverting Amplifier

Student Worksheet

In this activity you will learn how to connect an inverting amplifier circuit using an operational amplifier. You will use this circuit to calculate the value of a “mystery resistor”.

Theory

Operational amplifiers (op-amps) can be used in a number of different circuits that you will be investigating as you work through the course.

The circuit for an inverting amplifier contains an input resistor of resistance R_{IN} and a feedback resistor of resistance R_F , as shown in the circuit diagram below.

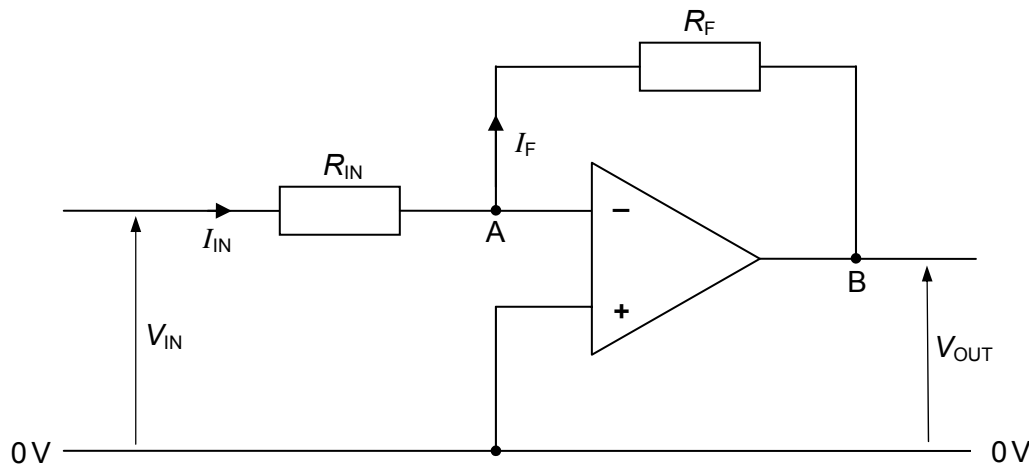

Work through the questions below to ensure that you understand how this circuit works. You should do this before you start to work with the apparatus.

- 1 State the approximate current at the inverting input of the op-amp.
- 2 From Kirchhoff's first law, state the relationship between I_{IN} and I_F .
- 3 The op-amp is not saturated. State the approximate potential difference between the inverting input and the non-inverting input of the op-amp.
- 4 Hence state the approximate potential of the inverting input.
- 5 Using your answer to 4, write down an expression for I_{IN} in terms of V_{IN} and R_{IN} .
- 6 Using your answer to 4, write down an expression for I_F in terms of V_{OUT} and R_F .
- 7 Hence show that the voltage gain of the circuit is given by the equation

$$\frac{V_{OUT}}{V_{IN}} = - \frac{R_F}{R_{IN}}.$$

You should make sure that you understand where the minus sign in this equation comes from.

The negative voltage gain is the reason why this amplifier circuit is called an inverting amplifier – a positive input voltage is “inverted” to give a negative output voltage, and a negative input voltage is “inverted” to give a positive output voltage.

Technical information

The op-amp that you have been given does not look like the circuit symbol. It has eight pins. The diagram and table below show you which pin corresponds to which terminal of the op-amp. You will need this information in order to connect the op-amp into a circuit.

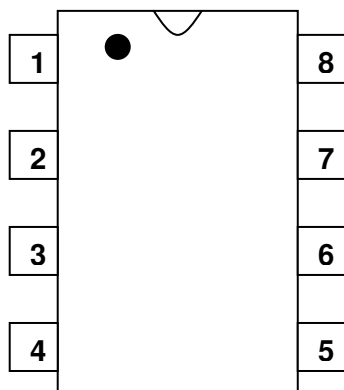

Pin number	Name of connection
1	
2	Inverting input
3	Non-inverting input
4	Negative power supply
5	
6	Output
7	Positive power supply
8	

You may ignore pins 1, 5 and 8.

In this experiment, the positive power supply should be at +9 V and the negative power supply should be at -9 V. (This means that there should be an 18 V potential difference between the two power terminals.)

Making measurements and observations

- Design an inverting amplifier circuit using only the apparatus supplied. You should draw your design in the form of a circuit diagram before you make any connections. In your circuit diagram you should
 - use the “mystery resistor” as the feedback resistor and the 10 k Ω resistor as the input resistor;
 - show the power supply connections to the op-amp;
 - show how you will measure V_{IN} and V_{OUT} ;
 - show how you will vary V_{IN} between -9 V and 9 V.
- Connect up the circuit you have drawn.
- Collect values of V_{IN} and V_{OUT} , where $-9\text{ V} \leq V_{IN} \leq 9\text{ V}$. Include error estimates in your table of results.

Analysing your data

Plot a graph of your data and use this graph to determine the voltage gain of the circuit. Hence determine the resistance R_F of the “mystery resistor”. Include an error estimate in your answer.

The Operational Amplifier as an Inverting Amplifier

Teaching Notes

Link to theory

28(h) *recall the main properties of the ideal operational amplifier (op-amp).*

28(k) *recall the circuit diagrams for both the inverting and non-inverting amplifier for single input.*

28(l) *show an understanding of the virtual earth approximation and derive an expression for the gain of inverting amplifiers.*

28(m) *recall and use expressions for the voltage gain of inverting and of non-inverting amplifiers.*

Key learning objectives

- To teach students the circuit for the inverting amplifier.
- To teach students the derivation of the equation for the voltage gain of an inverting amplifier.
- To provide practice at designing circuits and propagating errors.

Notes

This activity is designed to teach students, by practical means, about the inverting amplifier. It is not intended to reinforce or follow a theory lesson covering the inverting amplifier.

It is assumed that students will already have been taught about the op-amp, including the two inputs, the large open-loop gain, and the large input resistance.

As well as teaching students a new concept in a hand-on way, the activity also provides practice and reinforcement for the A2 practical skills of planning and the treatment of experimental errors.

Additional guidance for students

The expected circuit diagram is shown on the following page. Students may need help with some aspects of the circuit but they should be encouraged to work out as much of the circuit as possible for themselves. They should not normally be shown the whole circuit diagram.

Expected results

The graph should show the full range of values of V_{IN} from -9 V to $+9\text{ V}$. The graph should show that the output is saturated at both ends. The value of the gain should be -2 . The resistance of the “mystery resistor” should be $20\text{ k}\Omega$. Students should have small error bars on their graph and an error estimate in their answers for the gain and the resistance.

Possible extension work

Much of the work on op-amps in section 28 of the syllabus may be taught in this way.

Circuit diagram for the inverting amplifier.

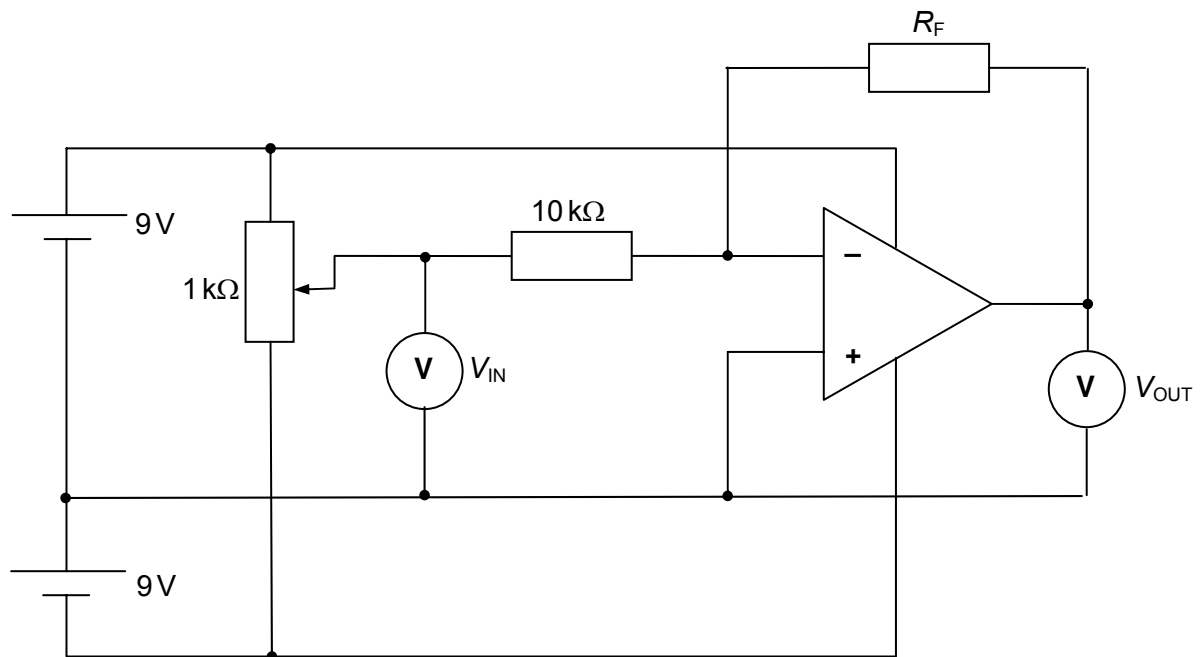

The Operational Amplifier as an Inverting Amplifier

Technical Notes

Apparatus requirements

- 1 **Operational amplifier.** A 741 or a 081FET op-amp would be suitable. The pins must be connected to terminals so that students may make connections to the leads without difficulty and without risk of short-circuits.
- 2 **Two 9 V batteries.**
- 3 **Two digital voltmeters,** capable of reading voltages up to 10 V. Digital multimeters would be suitable.
- 4 **1 k Ω potentiometer,** with terminals that allow students to make connections to the leads without difficulty. The potentiometer should be labelled with its resistance.
- 5 **10 k Ω resistor,** labelled with its resistance.
- 6 **20 k Ω resistor,** labelled “mystery resistor”.
- 7 **Four crocodile clips** to allow the leads to be connected to the resistors.
- 8 **Fourteen connecting wires.**

Cantilever Investigation

Student Worksheet

In this activity you will plan and carry out an investigation of the relationship between the length of a cantilever and the depression of the end.

Theory

A cantilever is a beam that is fixed horizontally at one end. When the other end is loaded with a mass m , it becomes depressed by a distance h .

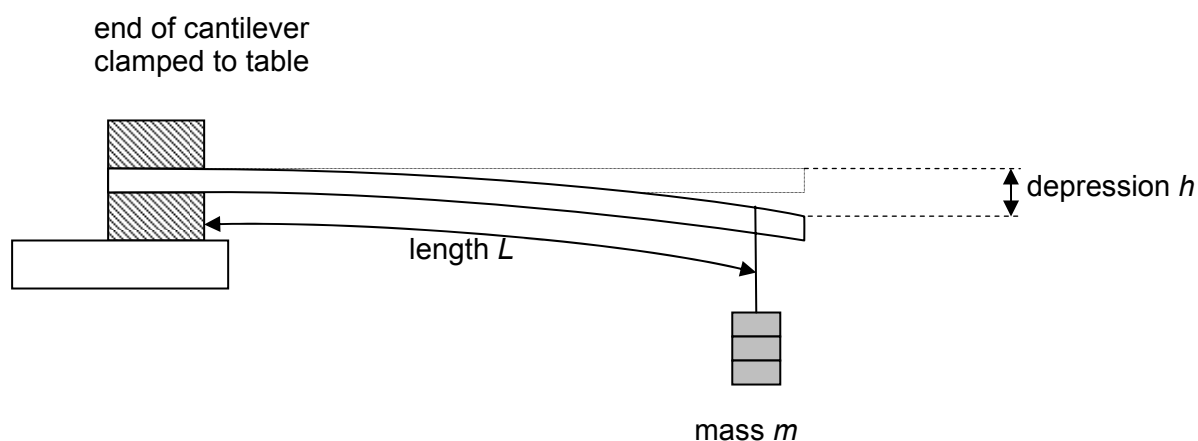

Theory suggests that the depression h is related to the length L of the cantilever by an equation of the form

$$h = aL^b$$

where a and b are constants.

Making measurements and observations

Plan an experiment to determine the values of the constants a and b using the apparatus provided. You should write the plan before carrying out the experiment. In your plan, you should

- 1 describe, with the aid of a diagram, how the apparatus is to be set up;
- 2 explain how h and L will be measured;
- 3 discuss the control of variables;
- 4 discuss any safety considerations.

After you have written your plan, you should use the apparatus provided to collect your data. Include error estimates in your table of results.

Analysing your data

Use a graph to determine the values of a and b . Include error estimates in your answers.

Evaluation

Describe the difficulties and sources of error that you encountered when following your plan. Describe what you would do differently if you were to repeat the experiment, and state how the experimental errors could be reduced.

Cantilever Investigation

Teaching Notes

Link to theory

This experiment does not link directly to the theory in the syllabus. However, it is a useful exercise for the reinforcement of practical skills.

Key learning objectives

- To reinforce planning skills.
- To provide experience of the use of log-log graphs for relationships in the form $y = ax^n$, with minimal guidance.
- To provide practice in the treatment and propagation of errors.

Notes

This practical is suitable for the end of the course. It is assumed that, by the time the students do this practical, they will already have been taught how to treat errors as described in the syllabus, and that they are familiar with planning experiments and with working with little guidance. This practical practices all of these skills.

Extra guidance should be given as necessary, as outlined below.

It is important that students write out their plans before starting to collect data, and that they stick to their written plans. In the examination, they will be required to write a plan and then to stop. The experiment will be less effective preparation for the examination if students are allowed to improvise as they proceed.

Additional guidance for students

Although students may find other ways to conduct the experiment, the following basic steps are expected.

- 1 The metre rule will be used as a cantilever. The string will be used to make a loop at the end of the metre rule, from which the masses can be hung.
- 2 The half metre rule will be used to measure h . It should be held in position with the retort stand, boss and clamp.
- 3 Rearranging the equation.

$$h = aL^b$$

$$\lg h = \lg(aL^b) = b \lg L + \lg a$$
 so there is a linear relationship between $\lg h$ and $\lg L$.
- 4 The graph should be $\lg h$ (y -axis) against $\lg L$ (x -axis).
- 5 $\lg a$ is the y -intercept of the graph and b is the gradient of the graph.

Expected results

The value of b should be 3, but the value of a will depend on the material and dimensions of the metre rule and on the mass used to load it. The students should have calculated error estimates in their answers.

Possible extension work

There is a great deal of extension work that can be done with the cantilever. The equation for the depression h of a cantilever is

$$h = \frac{4mgL^3}{Ebd^3}$$

where m is the load on the end of the cantilever, g is the acceleration of free fall, L is the effective length of the cantilever, E is the Young modulus of the material from which the cantilever is made, b is the width of the cantilever and d is its thickness.

The vertical oscillations of a loaded cantilever can also be investigated. The equation for the period T of these oscillations is

$$T = 2\pi \sqrt{\frac{4mgL^3}{Ebd^3}}$$

For both of these equations, a variety of experiments can be designed.

Cantilever Investigation

Technical Notes

Apparatus requirements

- 1 **Metre rule**, wooden or plastic, with a hole drilled through the middle at the 1.0 cm mark.
- 2 **Two blocks of wood** to hold the metre rule in the clamp.
- 3 **G-clamp**, with jaws large enough to clamp the metre rule, and the two block of wood, to the bench.
- 4 **Half-metre rule.**
- 5 **Stand, boss and clamp.**
- 6 **Small piece of string**, about 20 cm.
- 7 **100 g mass hanger with nine 100 g slotted masses.**

Note

This practical must be carried out at a place where the bench is strong and where there is plenty of space for the student to work.

Appendix 3: Useful resources

The following two books provide support and guidance for teaching practical skills in A level physics as well as containing more suggestions for practical activities, most of which are appropriate for this course.

Advanced Level Practical Work for Physics – Chris Mee and Mike Crundell. (Hodder and Stoughton ISBN 0-340-78248-5)

Advanced Physics Laboratory Book – Peter Warren (John Murray ISBN 0-7195-8054-4)

CIE publishes some books and booklets that also provide support and advice with respect to practical work

Teaching and Assessing Practical Skills in Science – Dave Hayward (CIE Publications)

Planning For Practical Science in Secondary Schools (CIE publications June 2002)

The CIE website <http://www.cie.org.uk> has many resources that are designed to support teachers. Of particular interest is a practical video that is available on-line through the teacher support site at <http://teachers.cie.org.uk>. There are also details about other, more general A level Physics text books in the **Resources** section relating to the 9702 A/AS level Physics course.

The Institute of Physics and Nuffield Curriculum Centre maintain a practical physics website at <http://www.practicalphysics.org>. This website contains over 300 suggestions for demonstrations and practical activities. This resource is free and open to all, although you may need to adapt the activities to suit your own needs.